

Using In-Band Channels for Management of Telecommunication Network Elements

Loop Telecom's "in-band" management system is described. This is a robust technology for the management of remote network elements from a centralized SNMP center sharing the same network with customer traffic.

Introduction

Telecommunication networks for the transport of customer voice and data traffic contains Network Elements (NE). Management of such NE, which includes configuration, performance monitoring, and alarm reporting, while usually local at time of installation, is normally from a central location, remote from each NE.

Local management is accomplished by using the front panel LCD display and push buttons, or by a terminal attached to the console port, Figure 1. Remote management is accomplished by connecting a remote terminal or workstation via a management channel, such as a dial-up modem, a leased line, or a LAN/WAN facility, Figure 2. In addition, Loop Telecom provides some of its products with "in-band" management capability, which allows the management channel to share the same transport facility as customer data, Figure 3.

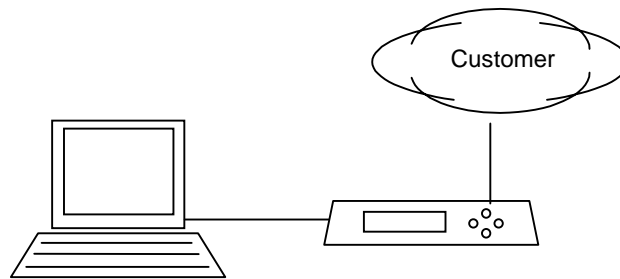

Figure 1 - Local Management

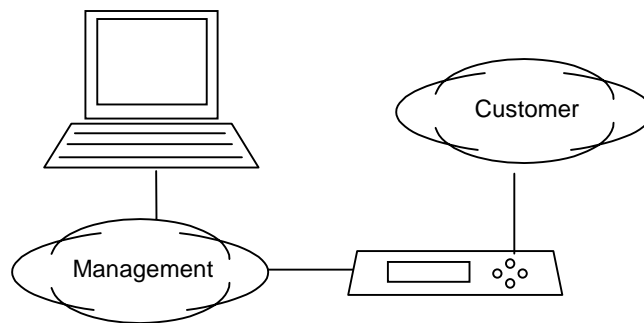

Figure 2 - Remote Management

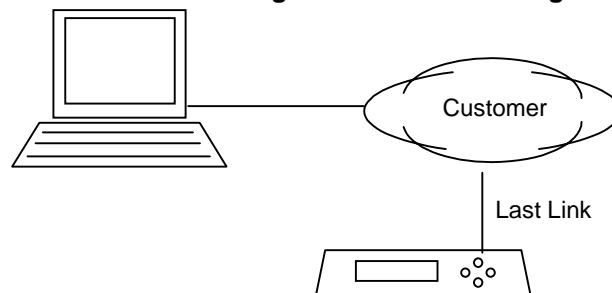

Figure 3 - In-Band Management

Description of Elements and Terms

Depending on the perspective, management terms take on different meanings. Remote management can mean management of a remote network element from the central office, or mean management from the Network Management Center (NMC). In-band management can mean the use of the “national bits” within time-slot 0, or can mean the use of a regular data time slot. The national bits are usually available only for the last access link but not for traversing a network, while a regular data time slot can traverse any network.

Loop Telecom’s “in-band” management system can traverse any network, providing central in-band SNMP management.

As a result, when the national bits located in time slot 0 are used, management from the NMC is usually not possible. This is because most digital networks, needing their own management, block customer’s time slot 0. Loop Telecom’s in-band management system, in addition to TS0, can also use any regular time slot. As a result, the management channel can traverse any network, providing central “in-band” management from the NMC.

Here, we will use the perspective of the Network Management Center (NMC) and use “in-band” to mean the use of a regular data time slot for the management channel. The advantages of this technology will be discussed later.

First, definitions are given to provide a common ground for discussion. See Figure 4.

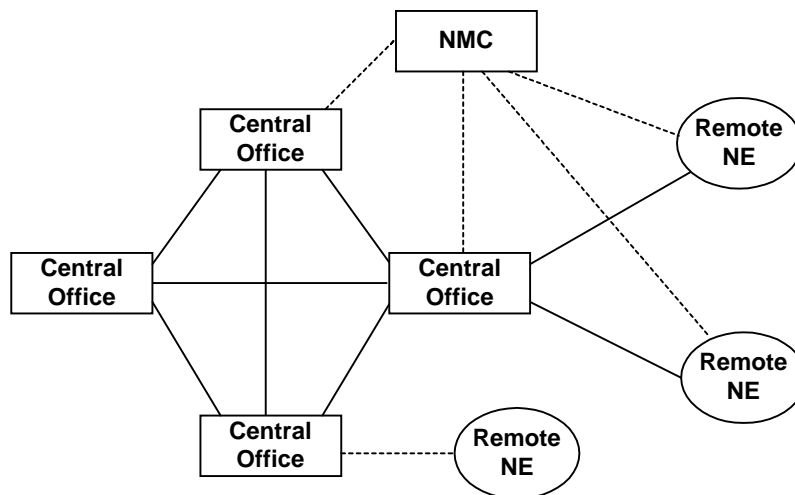

Figure 4 - Network Elements

Remote Network Elements

The network elements nearest the end users will be called the “remote network elements”. These network elements, connected to the central office with a single link, provide end users access to digital networks. For management, remote network elements can be accessed locally, from the central office, or from the NMC.

Central Office Network Elements

The network elements located in central offices, though still remote from the NMC, will be called the “central office network elements”. These network elements must also be accessed from the NMC. At edges of the network, they can also serve as conduits for the NMC to reach the remote network elements.

Network Management Center

The network management center (NMC) can be located anywhere. It must have communication links to every network element to monitor its health and to change its configuration in response to customer needs or in response to network faults. The communication links can be provided by a separate external network or by the same network as providing customer data service. One is called “external management network”, Figure 4, and the other “in-band management network”, Figure 5.

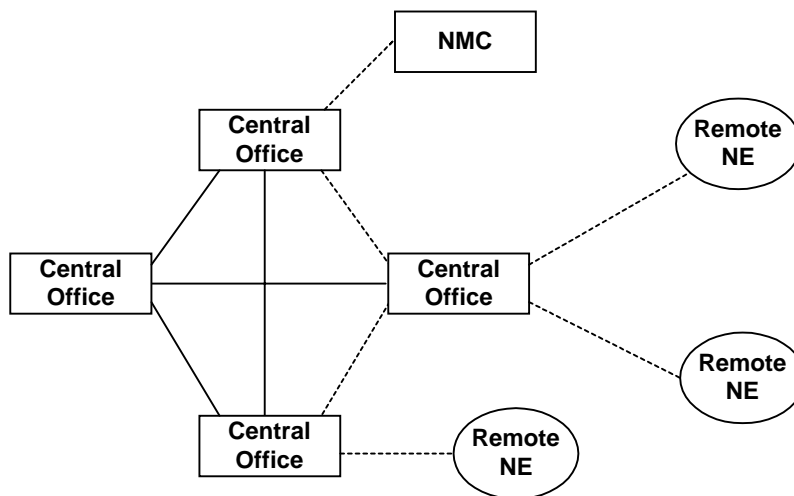

Figure 5 - In-Band Management

Advantage of Using In-Band Channels

Aside from the advantage of using a same network for customer voice and data signals and for the management of NE, the use of "in-band" channel allows management signals to traverse leased networks just as if they were customer data. With this technology, remote management becomes possible for many situations where a separate network for management either is not available or too expensive.

Risk Management Using In-Band

The obvious risk of using the same network for management and for customer data is that if the network fails for customer data, the management channel is also lost. This risk should be carefully considered and provisions made to address such situations. For the last link to the NE, either loss of the customer data link or the loss of the management link would require dispatch of repair personnel. For this last link, shown in Figure 3, therefore, this risk is acceptable.

Equipment for In-Band Management

Most NE are equipped with an Ethernet port and a SLIP port for remote management through a separate network, such as dial-up modem through PSTN, leased analog lines, or LAN/WAN data network. For "in-band" remote management, the NE must also have the capability of extracting the management channel from the same data stream as customer data. Furthermore, equipment must be available to insert the management channel into the data stream used for customer data.

In-Band Management Facility

In-band management facility allows the management channels to share the same facility as traffic. This results in considerable savings, particularly for skinny routes. Three requirements are necessary for the realization of the economy and flexibility of in-band management.

- A.** From the transport facility, network elements must be able to extract the management channel from traffic channels. Many network elements can extract such management information from the national bits in time-slot 0, but not from time slots used for traffic channels. Some vendors claim to have "in-band" management when national bits are meant. Loop Telecom equipment is capable to extract the management information either from the national bits or from a regular data channel, making possible in-band management from a central SNMP management center. Such network elements are said to be "in-band capable".
- B.** Availability of network elements that can easily insert and extract the management information into regular data channels of transport facilities. This further allows flexibility of the network designer to send management information partially over external facilities and partially over traffic facilities. This is called the "management gateway device", which combines the function of bridge/router, fractional CSU/DSU, and DCS (digital cross-connect system).
- C.** Capability of the data traffic network to carry the management information as traffic. In most leased transport facilities, the national bits in time-slot 0 are reserved for the owners of the facilities. Therefore, within global networks using leased third party networks, only Loop Telecom's in-band management technology can traverse such leased facilities.

Most network elements fail in one or more of the above. Loop Telecom equipment, by providing all three essential requirements for in-band management, gives network designers unprecedented flexibility and economy.

In-Band Capable Loop Telecom Equipment

Loop Telecom has “in-band capable” NE, both as equipment that can extract management data and as equipment that can insert management data into the customer data stream. The following equipment extract management data from the customer data stream..

- The Loop-E 1200 is a CSU/DSU and multiplexer for E1 and fractional E1 lines. As with the Loop-C 5500, remote units, if of the same brand, linked to this one can also be managed using the normal EOC channel.
- The Loop-V 3420 is a multiplexer that accepts multi-port plug-in cards, which include cards for the U interface (the physical interface of ISDN), the MDSL interface (the transport technology of HDSL), and the V.35 interface. Again, remote units linked to this one can be managed as well.
- The Loop-V 4200 Muxmaster can not only provide in-band management for all the plug-in cards, but also by extension, make use of the remote management capability of the plug-in cards to manage NE remote from the Loop-V 4200 and linked by a single span to the plug-in cards.
- Loop-V 4100
- Future Loop products will have in-band capability whenever appropriate

In addition, for inserting management data into the customer data stream, the Loop-V 4200 Muxmaster has an available plug-in card designed for this function, the Router, which is also a simple LAN bridge. Details on how to use these equipment follows.

Physical Set-Up Examples

Several examples will be given in order of complexity.

Example 1

In the simplest case, one Loop-V 4200 and one Loop-E 1200 are linked through an E1 network, Figure 6. The management terminal is local to the Loop-V 4200 and is connected to the Loop-V 4200 via a Router card plugged into the Loop-V 4200.

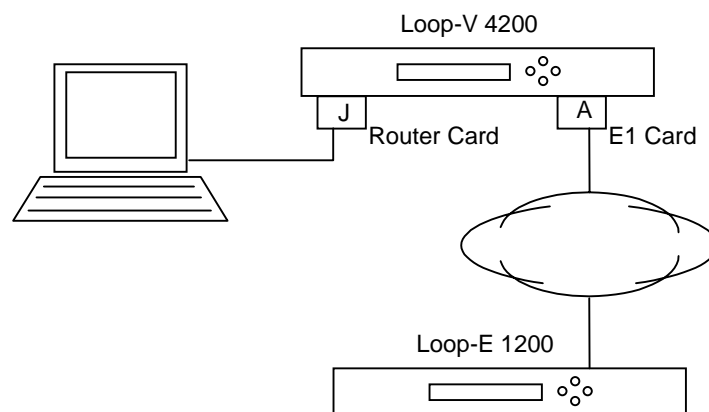

Figure 6 - Simple Case (Example 1)

Setup for Example 1

For the Loop-V 4200 setup, for the insertion of the management data into the E1 stream, from the Router card, one HDLC channel, out of a total of 16 available, is assigned to one time slot of the E1 line linking to the remote Loop-E 1200. First the Router card should be configured as BRIDGE as shown below.

If a port, LAN or WAN is configured with "Mode" BRIDGE, then the IPAddress and Mask are ignored. If configured as Router, then user must fill in the IPAddress and SubnetMask. In addition, the Frame type and whether RIP-I and RIP-II are disabled or enabled must be set. All configurations for vacant WANs are ignored. It is common to enter all 0's for these fields.

```

PORT CC RTR          === Port System(LAN1-WAN16) Setup === 14:08:49 06/13/2001
ARROW KEYS: CURSOR MOVE, Please Input: nnn.nnn.nnn.nnn, BACKSPACE to edit

NI      IPAddress      SubnetMask      Frame      RIP_I      RIP_II      Mode
LAN1    192.168.123.025 255.255.255.000 ETHERNET    DISABLE    ENABLE      BRIDGE
LAN2    140.133.025.023 255.255.000.000 ETHERNET    DISABLE    DISABLE     BRIDGE
WAN1    100.001.001.001 255.000.000.000 PPP          DISABLE    ENABLE      BRIDGE
WAN2    000.000.000.000 000.000.000.000 HDLC        DISABLE    DISABLE     BRIDGE
WAN3    000.000.000.000 000.000.000.000 HDLC        DISABLE    DISABLE     BRIDGE
WAN4    000.000.000.000 000.000.000.000 HDLC        DISABLE    DISABLE     BRIDGE
WAN5    000.000.000.000 000.000.000.000 HDLC        DISABLE    DISABLE     BRIDGE
WAN6    000.000.000.000 000.000.000.000 HDLC        DISABLE    DISABLE     BRIDGE
WAN7    000.000.000.000 000.000.000.000 HDLC        DISABLE    DISABLE     BRIDGE
WAN8    000.000.000.000 000.000.000.000 HDLC        DISABLE    DISABLE     BRIDGE
WAN9    000.000.000.000 000.000.000.000 HDLC        DISABLE    DISABLE     BRIDGE
WAN10   000.000.000.000 000.000.000.000 HDLC        DISABLE    DISABLE     BRIDGE
WAN11   000.000.000.000 000.000.000.000 HDLC        DISABLE    DISABLE     BRIDGE
WAN12   000.000.000.000 000.000.000.000 HDLC        DISABLE    DISABLE     BRIDGE
WAN13   000.000.000.000 000.000.000.000 HDLC        DISABLE    DISABLE     BRIDGE
WAN14   000.000.000.000 000.000.000.000 HDLC        DISABLE    DISABLE     BRIDGE
WAN15   000.000.000.000 000.000.000.000 HDLC        DISABLE    DISABLE     BRIDGE
WAN16   000.000.000.000 000.000.000.000 HDLC        DISABLE    DISABLE     BRIDGE

<< Press ESC key to return to previous menu >>

```

An example of the terminal screen for controller system setup connected to the Loop-V 4200 for this setup is shown below.

```

LOOP V4200 CONTROLLER      === System Setup ( MAP ) ===                09:25:55 05/05/1999
ARROW KEYS: CURSOR MOVE, TAB: ROLL OPTIONS
      PORT A  PORT B  PORT C  PORT D  PORT E  PORT F  PORT H  PORT J  PORT K
TIME  E1      E1      E1      E1      T1      T1      T1      ROUTER  T1
SLOT  NON-CAS  NON-CAS  NON-CAS  NON-CAS  NON-CAS  NON-CAS  NON-CAS  NON-CAS  NON-CAS
=====
  1  d  J 01 d  B 01 d      00 d  D 01 d      00 d  F 01 d      00 d  A 01 d  K 01
  2  d      00 d  B 02 d      00 d  D 02 d      00 d  F 02 d      00 d      00 d  K 02
  3  d      00 d  B 03 d      00 d  D 03 d      00 d  F 03 d      00 d      00 d  K 03
  4  d      00 d  B 04 d      00 d  D 04 d      00 d  F 04 d      00 d      00 d  K 04
  5  d      00 d  B 05 d      00 d  D 05 d      00 d  F 05 d      00 d      00 d  K 05
  6  d      00 d  B 06 d      00 d  D 06 d      00 d  F 06 d      00 d      00 d  K 06
  7  d      00 d  B 07 d      00 d  D 07 d      00 d  F 07 d      00 d      00 d  K 07
  8  d      00 d  B 08 d      00 d  D 08 d      00 d  F 08 d      00 d      00 d  K 08
  9  d      00 d  B 09 d      00 d  D 09 d      00 d  F 09 d      00 d      00 d  K 09
 10  d      00 d  B 10 d      00 d  D 10 d      00 d  F 10 d      00 d      00 d  K 10
 11  d      00 d  B 11 d      00 d  D 11 d      00 d  F 11 d      00 d      00 d  K 11
 12  d      00 d  B 12 d      00 d  D 12 d      00 d  F 12 d      00 d      00 d  K 12
 13  d      00 d  B 13 d      00 d  D 13 d      00 d  F 13 d      00 d      00 d  K 13
 14  d      00 d  B 14 d      00 d  D 14 d      00 d  F 14 d      00 d      00 d  K 14
 15  d      00 d  B 15 d      00 d  D 15 d      00 d  F 15 d      00 d      00 d  K 15
 16  d      00 d  B 16 d      00 d  D 16 d      00 d  F 16 d      00 d      00 d  K 16

<< ESC key to previous menu, SPACE key to another page >>                PAGE1
  
```

Then for the extraction of the management data from the E1 stream, the configuration of the Loop-E 1200 will have that same time slot assigned to "m", as shown in the front panel LCD.

```

MAP1>[iiiiiiiimi1111122333444ddddd]01
      *IDLE DTE-1 -2 -3 -4 D&I m 12:768K
  
```

If a terminal is used, an example of the terminal screen connected to the Loop-E 1200 for this setup is shown below.

```

=== Local System Setup ===                09:09:15 04/18/94
ARROW KEYS : CURSOR MOVE , TAB : ROLL UP
DS0-MAP:ACTIVE MAP = MAP1
MAP1=[iiiiiiiimi1111122333444ddddd] MAP2=[iiiiiiiiiiiiiiiiiiiiiiiiiiiiiiiiiiii]
SWITCH TIME = MAP1 00:00-12:00          MAP2 12:00-00:00
LINE:CODE=HDB3 CRC=ON  RAI=ON  FDL=ON  IDLE=D5          S-Bit=Sa4
D&I :CODE=HDB3 CRC=ON          <MAP1>  0:  0K  <MAP2>  0:  0K
      (RATE) <MAP1>          <MAP2>          (CLOCK)  (DATA)  (INTERFACE)  (RTS)  (TTM)
DTE1: 64K  0:  0K  0:  0K  NORMAL  NORMAL  EIA530/RS449  ACTIVE  OFF
DTE2: 64K  0:  0K  0:  0K  NORMAL  NORMAL  EIA530/RS449  ACTIVE  OFF
MAST-CLOCK: LINE          2nd-CLOCK:LINE          EXT-FREQ: 2.048Mbps  CURRENT=2nd-CLOCK
RS-232 PORT: BAUD=9600  DATA=8  STOP=1  PAR=NONE  XON-XOFF=OFF  INTERF=TERMINAL
DIAL-OUT SETUP:
  PRIMARY DIALSTRING : ATDT                (32 char)
    START TIME : 08:00          STOP TIME: 07:59
  SECONDARY DIALSTRING: ATDT                (32 char)
    START TIME : 08:00          STOP TIME: 07:59
  INACTIVITY TIMEOUT : 0  MINUTES
DEVICE NAME: LOOP-E-01          (20 char)

STATUS:

<< Press ESC Key to Return to Main Menu >>
  
```

Then, before the terminal can communicate to the remote Loop-E 1200, the IP address of the Loop-E 1200 must be set. The terminal will then use that IP address to reach the Loop-E 1200

Example 2

In the next example, several Loop NE products are linked to a single central Loop-V 4200, Figure 7. The management terminal local to the Loop-V 4200 is able to manage all these NE.

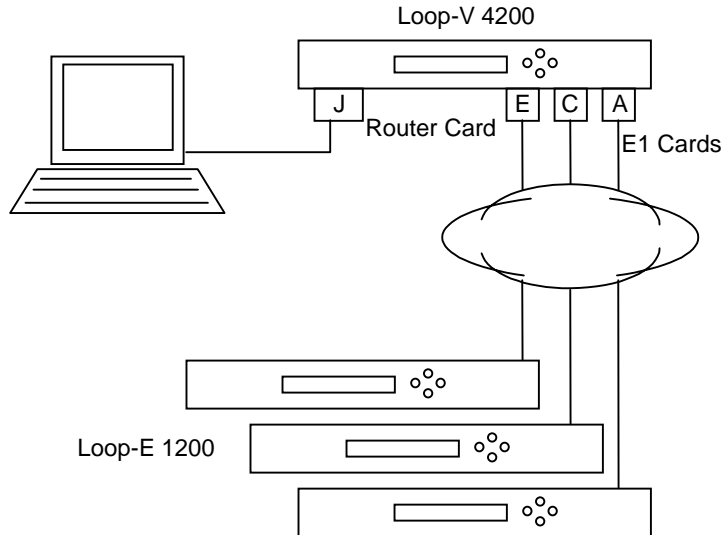

Figure 7 - Management of Multiple Units (Example 2)

Setup for Example 2

For this setup, each of the remote NE will have a different HDLC channel assigned to its E1 link. An example of the terminal screen connected to the Loop-V 4200 for this setup is shown below.

```

LOOP V4200 CONTROLLER    === System Setup ( MAP ) ===                09:25:55 05/05/1999
ARROW KEYS: CURSOR MOVE, TAB: ROLL OPTIONS
      PORT A  PORT B  PORT C  PORT D  PORT E  PORT F  PORT H  PORT J  PORT K
TIME  E1      E1      E1      E1      T1      T1      T1      BRIDGE T1
SLOT  NON-CAS NON-CAS NON-CAS NON-CAS NON-CAS NON-CAS NON-CAS      NON-CAS
=====
  1   d   J 01 d   B 01 d   00 d   D 01 d   00 d   F 01 d   00 d   A 01 d   K 01
  2   d   00 d   B 02 d   J 02 d   D 02 d   00 d   F 02 d   00 d   C 02 d   K 02
  3   d   00 d   B 03 d   00 d   D 03 d   J 03 d   F 03 d   00 d   E 03 d   K 03
  4   d   00 d   B 04 d   00 d   D 04 d   00 d   F 04 d   00 d   00 d   K 04
  5   d   00 d   B 05 d   00 d   D 05 d   00 d   F 05 d   00 d   00 d   K 05
  6   d   00 d   B 06 d   00 d   D 06 d   00 d   F 06 d   00 d   00 d   K 06
  7   d   00 d   B 07 d   00 d   D 07 d   00 d   F 07 d   00 d   00 d   K 07
  8   d   00 d   B 08 d   00 d   D 08 d   00 d   F 08 d   00 d   00 d   K 08
  9   d   00 d   B 09 d   00 d   D 09 d   00 d   F 09 d   00 d   00 d   K 09
 10  d   00 d   B 10 d   00 d   D 10 d   00 d   F 10 d   00 d   00 d   K 10
 11  d   00 d   B 11 d   00 d   D 11 d   00 d   F 11 d   00 d   00 d   K 11
 12  d   00 d   B 12 d   00 d   D 12 d   00 d   F 12 d   00 d   00 d   K 12
 13  d   00 d   B 13 d   00 d   D 13 d   00 d   F 13 d   00 d   00 d   K 13
 14  d   00 d   B 14 d   00 d   D 14 d   00 d   F 14 d   00 d   00 d   K 14
 15  d   00 d   B 15 d   00 d   D 15 d   00 d   F 15 d   00 d   00 d   K 15
 16  d   00 d   B 16 d   00 d   D 16 d   00 d   F 16 d   00 d   00 d   K 16
<< ESC key to previous menu, SPACE key to another page >>                PAGE1
    
```

Then for each NE linked to the Loop-V 4200, the configuration will have a time slot assigned to “m” as in the first example.

Then, before the terminal can communicate to each of the remote NE, the IP address of each remote NE must be set. The terminal will then use those IP addresses to select a particular NE for management.

Example 3

In the first example, although a terminal connected to the Router card of the Loop-V 4200 can manage the NE down stream using in-band techniques, the management of the Loop-V 4200 itself needs another terminal connected either to its console port or Ethernet port. This need for extra terminal can be removed by using a local Ethernet Hub, as shown in Figure 8. The case where more than one NE is attached to the Loop-V 4200 follows the same connections as Example 2.

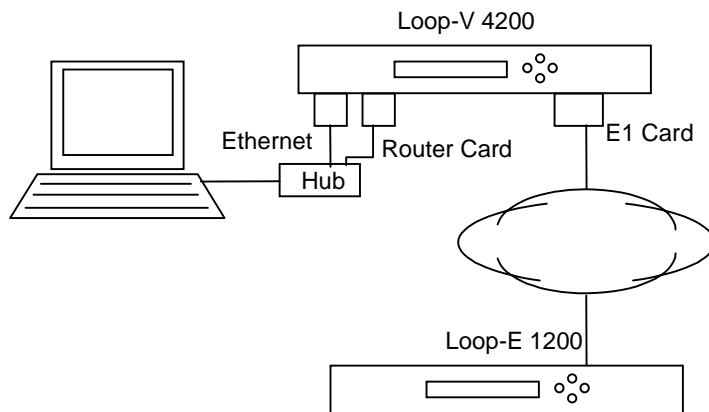

Figure 8 - Managing Local & Remote Units (Example 3)

Setup for Example 3

The setup for the NE is the same as in example 1. In addition, the Loop-V 4200 must now have an IP address. The terminal can then use the IP address to select the unit for management.

Setup for Example 4

The remote unit is also a V4200, no other NE connected to this V4200 is managed.

Set-Up at the Remote Unit:

The DS0 from the router module at point A is coming in on a T1 card in Slot A, TS#10. The crossconnect on the V4200-9 is as shown below in red.

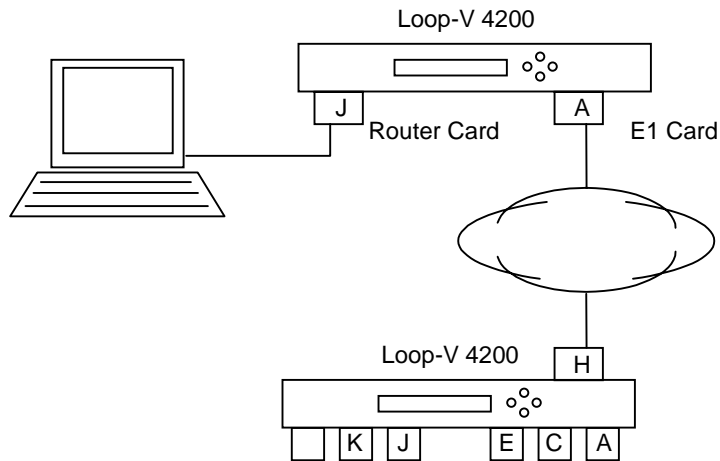

Figure 9 – Setup at the Remote Unit (Example 4)

```

LOOP V4200 CONTROLLER   === System Setup ( MAP ) ===           04:33:56 04/05/2002
ARROW KEYS: CURSOR MOVE, TAB: ROLL OPTIONS
  PORT A  PORT B  PORT C  PORT D  PORT E  PORT F  PORT H  PORT J  PORT K  PORT Z
TIME FE1
SLOT CAS
=====
 1  d   00
 2  d   00
 3  d   00
 4  d   00
 5  d   00
 6  d   00
 7  d   00
 8  d   00
 9  d   00
10  d z  01
11  d   00
12  d   00
13  d   00
14  d   00
15  d   00
16  d   00
=====
                                d A  10
<< ESC key to previous menu, SPACE key to another page >>           PAGE1
  
```

Example 5

If the terminal in previous examples is to be remote from the local Loop-V 4200, then the remote terminal needs another Loop-V 4200 to insert the management data. At the local Loop-V 4200, two Router cards are needed, one to extract the management data from the remote terminal, and another to re-insert the management data for downstream NE, Figure 9. An Ethernet Hub is used to allow interconnection of the Router cards and the Ethernet port of the local Loop-V 4200 itself.

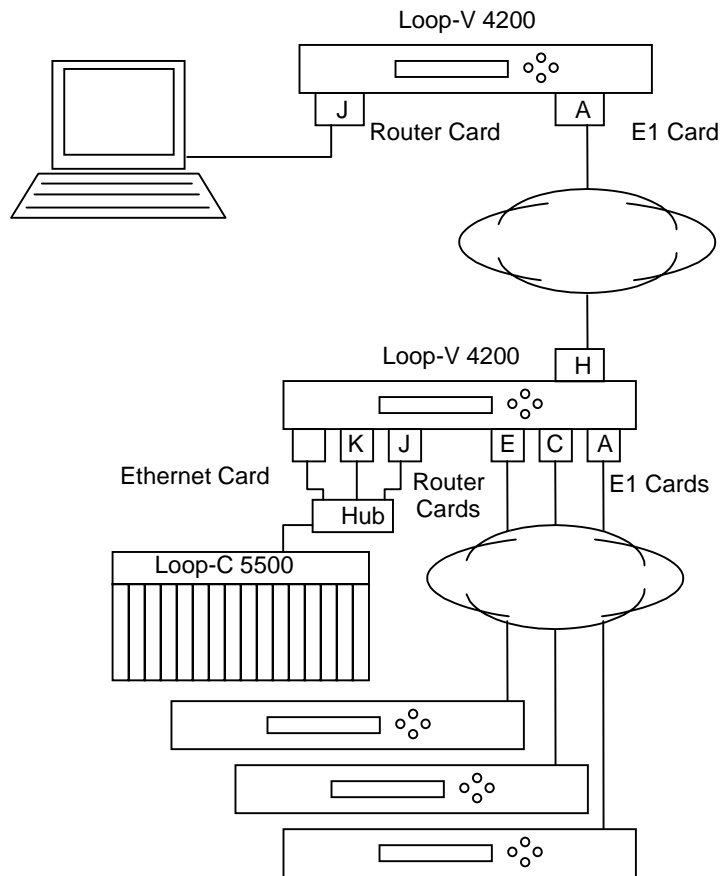

Figure 10 Remote Management of Multiple Units (Example 5)

Setup for Example 5

The remote terminal and the remote Loop-V 4200 will be setup as in example 1, except with 2 Router cards. One HDLC channel will be assigned to the incoming management data from the E1 line linking to the remote management site. Other HDLC channels will be assigned to the E1 lines linking the NE to the local Loop-V 4200. As in previous examples, all NE will be assigned IP addresses.

```

LOOP V4200 CONTROLLER      === System Setup ( MAP ) ===           09:25:55 05/05/1999
ARROW KEYS: CURSOR MOVE, TAB: ROLL OPTIONS
      PORT A  PORT B  PORT C  PORT D  PORT E  PORT F  PORT H  PORT J  PORT K
TIME  E1      E1      E1      E1      T1      T1      T1      ROUTER  T1
SLOT  NON-CAS  NON-CAS  NON-CAS  NON-CAS  NON-CAS  NON-CAS  NON-CAS  NON-CAS  NON-CAS
=====
 1  d  J 01 d  B 01 d    00 d  D 01 d    00 d  F 01 d    00 d  A 01 d  K 01
 2  d    00 d  B 02 d    J 02 d  D 02 d    00 d  F 02 d    00 d  C 02 d  K 02
 3  d    00 d  B 03 d    00 d  D 03 d    J 03 d  F 03 d    00 d  E 03 d  K 03
 4  d    00 d  B 04 d    00 d  D 04 d    00 d  F 04 d    J 04 d  H 04 d  K 04
 5  d    00 d  B 05 d    00 d  D 05 d    00 d  F 05 d    00 d    00 d  K 05
 6  d    00 d  B 06 d    00 d  D 06 d    00 d  F 06 d    00 d    00 d  K 06
 7  d    00 d  B 07 d    00 d  D 07 d    00 d  F 07 d    00 d    00 d  K 07
 8  d    00 d  B 08 d    00 d  D 08 d    00 d  F 08 d    00 d    00 d  K 08
 9  d    00 d  B 09 d    00 d  D 09 d    00 d  F 09 d    00 d    00 d  K 09
10  d    00 d  B 10 d    00 d  D 10 d    00 d  F 10 d    00 d    00 d  K 10
11  d    00 d  B 11 d    00 d  D 11 d    00 d  F 11 d    00 d    00 d  K 11
12  d    00 d  B 12 d    00 d  D 12 d    00 d  F 12 d    00 d    00 d  K 12
13  d    00 d  B 13 d    00 d  D 13 d    00 d  F 13 d    00 d    00 d  K 13
14  d    00 d  B 14 d    00 d  D 14 d    00 d  F 14 d    00 d    00 d  K 14
15  d    00 d  B 15 d    00 d  D 15 d    00 d  F 15 d    00 d    00 d  K 15
16  d    00 d  B 16 d    00 d  D 16 d    00 d  F 16 d    00 d    00 d  K 16

<< ESC key to previous menu, SPACE key to another page >>           PAGE1

```

Side Bar - Management Topologies

Management on Site

When network elements are first installed, on site local management is used for initial set-up and commissioning. This is accomplished by using either the front panel or a locally connected terminal. After commissioning, monitoring and subsequent changes of set-up are usually accomplished from a central site, which is preferably the NMC.

Front Panel – Figure 11

Using the key pads and LCD display on the front panel, local management is possible.

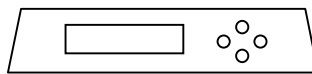

Figure 11 - Management from Front Panel

Terminal – Figure 12

More user friendly is the use of a VT100 or the equivalent of a PC running terminal emulation software. With a terminal, the entire set-up menu can be displayed at once. Moving the cursor, users can easily move to the desired menu item and select the proper choice.

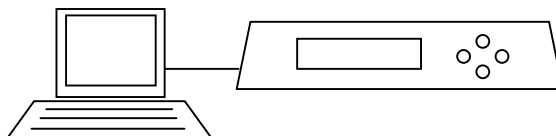

Figure 12 – Management

Management from Central Office

From the central office, management of the remote network element can be by external network or in-band. (See external network choices in the next section.) Because the remote network element is usually connected to a central office network element by a single transport link, the remote network element can be managed from the central office by using the national bits, or their equivalent in other systems.

Compared to management from the NMC, management from the central office is still cumbersome, or inaccessible, under some conditions. Furthermore, unlike the NMC, the status of the entire network is not available at the central office.

The available channel for management can be either in the overhead bits or a regular data time slot.

Overhead Bits for management – Figure 13

Within a digital transmission facility, there are bits set aside for network management use. These bits are called “national bits” for E1, FDL for T1, M-Channel for ISDN, and EOC for HDSL systems. So long as the network will carry these bits to reach the remote network element, these bits can be used for management. For the last link from the central office to the remote network element, this would be true. Therefore, this method is commonly used for managing the remote network element from the central office.

In traversing a digital network, these overhead bits are used for internal network management and are not available for management of remote network elements.

Management from NMC

Management of the digital network from a central site, the NMC, is a requirement of most networks. This is where the operation of the entire network can be observed and re-configured as needed. Reaction to customer needs and to network faults are best handled at the NMC.

To reach the remote network element from the NMC, either an external network or an “in-band” method available from Loop Telecom is used.

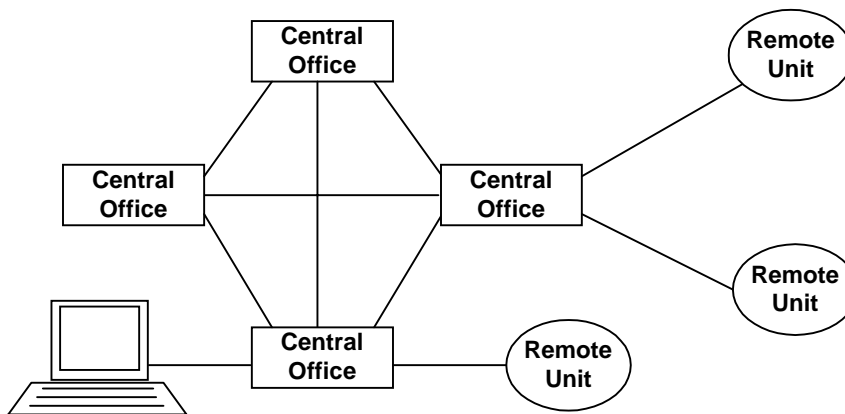

Figure 13 - Reaching the Remote NE from Central Office

External Network

Because overhead bits, such as the national bits Sa to Sd in time slot 0 of E1, cannot pass through most national networks, external networks are commonly used for management of remote network elements. Choices for the external network are (a) dial-up using modems and PSTN, (b) leased line using modems, and (c) LAN and WAN.

Dial-Up – Figure 14

Using modems, the network designer can utilize the PSTN (public switched telephone network) for the provisioning of the management network. For each network element, a local modem is attached to the console port. Each of these elements can thus be reached by dialing from a modem at the NMC.

This choice is seldom used because it cannot give continuous status of the network. A dial-back scheme must be provided for reporting of remote faults.

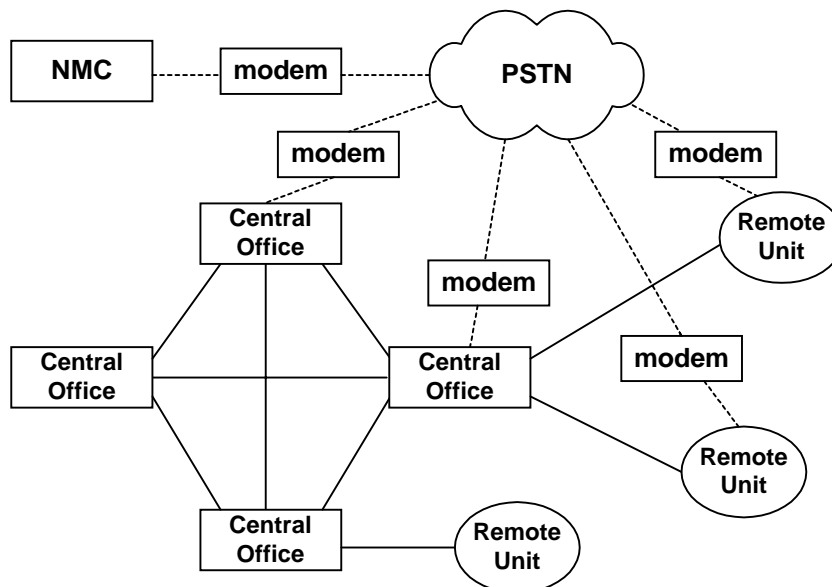

Figure 14 - Reaching the Remote NE Using Dial-Up

Leased Line – Figure 15

Instead of using the PSTN, a leased line network can be used. In this case, to reach each network element from the management center, a pair of modems, connected with a leased line, is used.

Using leased line to reach every network element is a significant expense for the NMC.

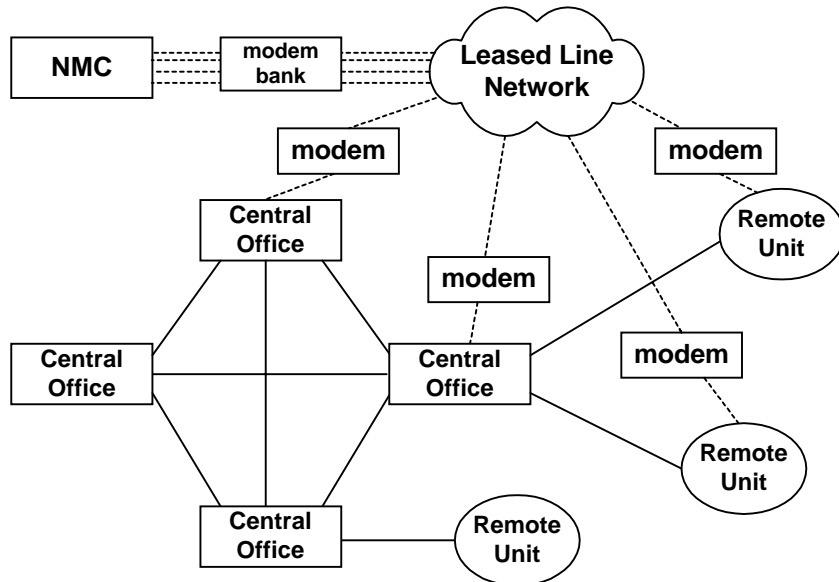

Figure 15 - Reaching the Remote NE Using Leased Line

LAN/WAN – Figure 16

The Ethernet port of the network element can also be used for network management. Remote management is possible by using LAN and WAN networks independent of the customer data network.

When a LAN with WAN interconnections are already available, this would be a good choice. Else, construction of a LAN/WAN network just for management would also be a significant expense.

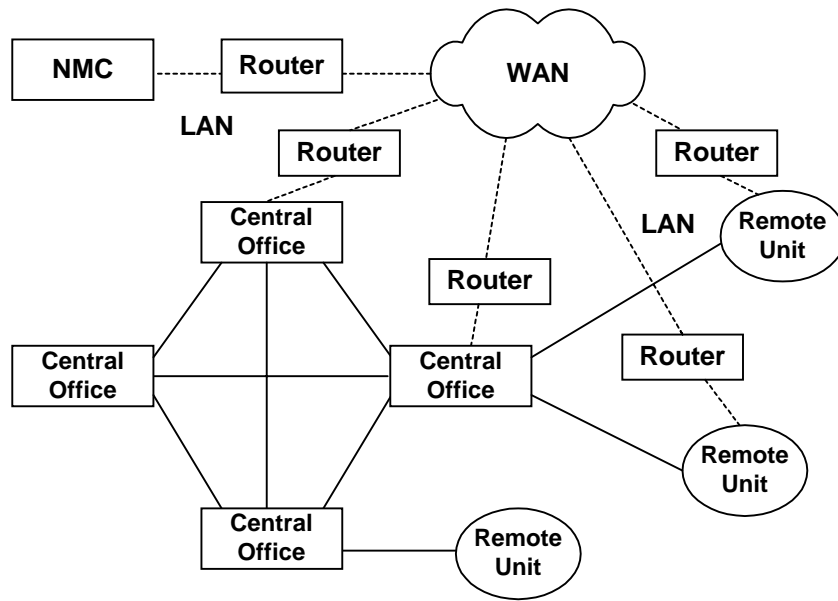

Figure 16 - Reaching the Remote NE Using LAN/WAN Network

In-Band – Figure 17

In band provides the most economical and convenient method of management from the NMC. This of course requires satisfying the three conditions outlined in the section “In-Band Management Facility”. Loop Telecom products satisfy these conditions and provide network operators with a management “gateway device” for convenient and economical management capability.

The gateway device takes the place of the router in the LAN/WAN solution for network management. By utilizing a data time slot for management, the gateway device allows management information to traverse a digital network just like any data. Therefore, this method provides connectivity of management information in any network architecture.

With the ability to enter and leave the “in-band” channel, the network administrator can elect to route the management channel over any portion of the network.

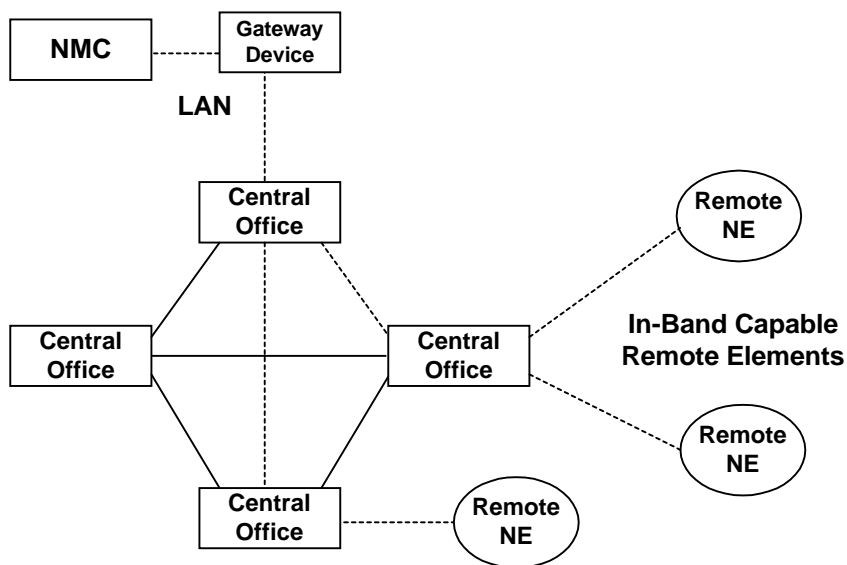

Figure 17 - Reaching the Remote NE Using In-Band Technology

Management Gateway Details

The Loop Telecom Management Gateway has within it HDLC channel concentration capability, Figure 18. From the SNMP management workstation, IP packets encapsulated within Ethernet packets are extracted and encapsulated into one of 16 available HDLC channels. The intended network element, which must be “in-band capable”, extracts the management IP packets from the received HDLC channel.

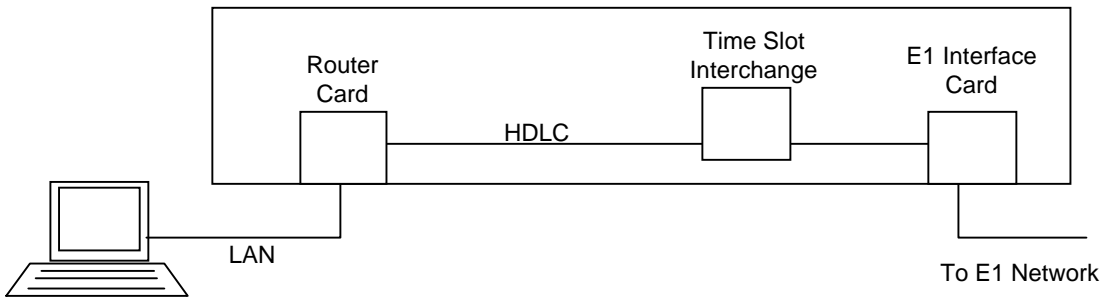

Figure 18 - Reaching the Remote NE from Central Office

When the DS0 time slot reaches the remote network element, this “in-band capable” unit can extract the IP packet from the HDLC channel and send to the management module to perform management functions, Figure 19.

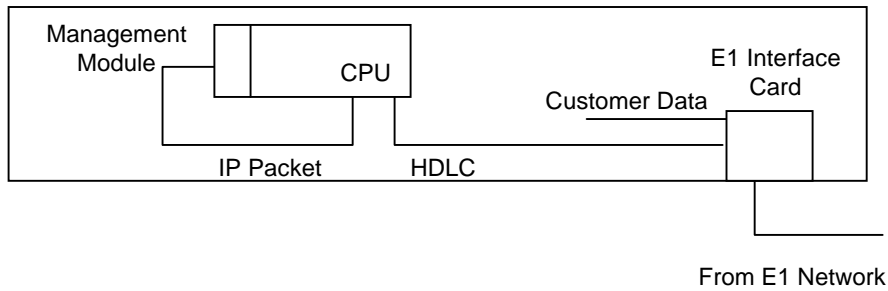

Figure 19 - In-Band Technology Details, Remote Element