



Loop-AM3440 Access DCS-MUX

AM3440-A



AM3440-B



AM3440-C



Description

The Loop-AM3440-A/B/C series are Access DCS-MUXs that combine various digital access interfaces into E1 or T1 lines for convenient transport and switching. The Loop-AM3440 Access DCS-MUX provides access for a variety of TDM, IP, and voice interfaces detailed on next page. These interfaces are compatible with other Loop products. Using these products, a DTE interface can be extended over copper wire pairs or any E1/T1 transport facility. For each Quad E1/T1 plug-in card, each card can have as many as DS0 124/96 time slots from G.SHDSL, RS232, X.21, V.35, V.36 and EIA530/RS449 interfaces, which can be multiplexed to fill 4 E1/T1 lines. AM3440 also supports fiber optical plug-in card, which can be used to aggregate up to 4 E1 channels onto a single fiber optical interface to connect with other AM3440 or O9310.

Each of the 3 models of AM3440, the A, the B, and the C, has a number of plug in slots in single slot size and mini size as shown in table at left. Card size to slot compatibility detailed on next page.

Features

- Full front access (ETSI) Shelf
- Support of DS0 DACS (Digital Access Cross-Connect System) with full cross-connect
- Dual controller, dual power with load sharing
- 1 for 1 protection, Y-BOX
- 1 for 1 protection, E1, T1, FOM
- PDH ring protection, QE1, QT1, FOM, Mini QE1
- Console, Telnet, SNMP, and Inband management support
- Craft interface port for connection to external LCD display
- Compatible to a SNMP based GUI network management system and supported by LoopView and Loop iNMS
- Three types of chassis available: AM3440-A/AM3440-B/AM3440-C
- All the plug-in cards are hot-pluggable

Item	AM3440-A	AM3440-B	AM3440-C
Chassis	5U	2.5U	3U
# of Mini-slots	4	4	4
# of Single slots	12	3	5
Max. E1 Channels	64	28	36
Max. T1 Channels	52	16	24
Cross-Connect Backplane Capacity	128 Mbps	56 Mbps	72 Mbps

This unit is a full cross-connect and can act as a mini DACS. This means that one or more of the WAN ports can be used as a Drop & Insert function with fractional E1/T1 lines, which can be muxed into a full E1/T1 line.

Redundancy is available in dual CPU controller and power supply options, making it an excellent fit for critical applications. Although the chassis does not contain and has no need for fan cooling, an external fan tray is available.

The AM3440 supports local control and diagnostics by using an external 2-line by 40-character LCD display and keypads, or by using a VT-100 terminal connected to the console port. The AM3440 also supports Ethernet, Telnet, and SNMP, so that it can be controlled and diagnosed from remote locations as well. An in-band management channel with GUI is available. In addition to the LCD display, there is LED indication for all plug-in cards.

Finally, the AM3440 consists of a rugged reinforced aluminum chassis, giving this equipment a more durable structure and a longer physical life.

Loop-AM3440 cards:

The Mini-Slot Cards plug into the Mini-Slots of the AM3440. The Single-Slot Cards plug into single slots, and the Dual-Slot Cards plug into two adjacent single slots.

	Plug-in cards	AM3440-A	AM3440-B	AM3440-C	
Mini-Slot	1-channel E1 (Single E1 interface)	√	√	√	
	1-channel T1 (Single T1 interface)	√	√	√	
	Mini Quad E1 (Four E1 interfaces)	√	√	√	
	1-channel E1 ATM/Frame Relay	√	√	√	
	1-channel T1 ATM/Frame Relay	√	√	√	
	Fiber optical interface	√	√	√	
	1-channel X.21	√	√	√	
	1-channel V.35	√	√	√	
	1-channel RS232	√	√	√	
	1-channel EIA530	√	√	√	
	Quad 2W/4W E&M (Four E&M voice interfaces)	×	√	√	
	QFXS/QFXO (Four FXS/FXO voice interfaces)	×	√	√	
	2-LAN port/32 WAN port Router	√	√	√	
	2-LAN port/64 WAN port Router-A	√	√	√	
	3-channel Terminal Server	√	√	√	
	Single-Slot	3-channel E1	√	√	√
		4-channel E1	√	√	√
4-channel T1		√	√	√	
2-channel G.SHDSL (2 pairs) w/o line power		√	√	√	
4-channel G.SHDSL (1 pair) w/o line power		√	√	√	
8-channel G.703 card at 64 Kbps data rate		√	√	√	
8-channel Dry Contact I/O		√	√	√	
8-channel Dry Contact I/O type B		√	√	√	
8-channel 2W/4W E&M		√	√	√	
12-channel FXS		√	√	√	
12-channel FXO		√	√	√	
12-channel Magneto		√	√	√	
Conference card		√	√	√	
1-channel low speed optical (C37.94)		√	√	√	
4-channel low speed optical (C37.94)		√	√	√	
8-channel RS232 with X.50 subrate		√	√	√	
8-LAN-port/ 64-WAN-port Router-B		√	√	√	
4-channel TDMoE		√	√	√	
8-channel Data Bridge*		√	√	√	
Dual-Slot	6-channel X.21/V.11	√	√	√	
	6-channel V.35	√	√	√	
	6-channel V.36	√	√	√	
	6-channel EIA530/RS449 card	√	√	√	
	5-channel RS232 with X.50 subrate	√	√	√	
	2-channel G. SHDSL (2 pairs) with line power	√	×	×	
	4-channel G. SHDSL (1 pair) with line power	√	×	×	
	24-channel FXS	√	√	√	
	24-channel FXO	√	√	√	

Note: √ = Supported

× = Not supported

* Future Option

Ordering Information

To specify options, choose from the list below:

Note:

1. RoHS compliant units are identified by the letter **G** appearing immediately at the end of ordering code.
2. AM3440 chassis types:
 - AM3440-CHA:** 5U chassis with 128 Mb/s cross-connect capacity backplane
 - AM3440-CHB:** 2.5U chassis with 56 Mb/s cross-connect capacity backplane
 - AM3440-CHC:** 3U chassis with 72 Mb/s cross-connect capacity backplane

Model (non RoHS compliant)	Model (RoHS compliant)	Description	Note
Main Unit			
Loop-AM3440-CHA	Loop-AM3440-CHA- G	Wideband Main Unit without CPU, power and plug-in cards	AM3440-A, B, C type Chassis. 19"/23" ear mount included. Note: For other ear mount requests, please contact your nearest Loop sales representative.
Loop-AM3440-CHB	Loop-AM3440-CHB- G	Wideband Main Unit without CPU, power and plug-in cards	
Loop-AM3440-CHC	Loop-AM3440-CHC- G	Wideband Main Unit without CPU, power and plug-in cards	
Main Unit for DS0 SNCP function			
Loop-AM3440-CHAJ	Loop-AM3440-CHAJ- G	Wideband Main Unit without CPU, power and plug-in cards, applicable to use with 3E1 card	Must order AM3440-CHAJ for DS0 SNCP function
Loop-AM3440-CHCJ	Loop-AM3440-CHCJ- G	Wideband Main Unit without CPU, power and plug-in cards, applicable to use with 3E1 card	Must order AM3440-CHCJ for DS0 SNCP function Future Option
CPU Module			
Loop-AM3440-CCA-T	Loop-AM3440-CCA-T- G	CPU card with T1 External Clock (order two for redundancy)	
Loop-AM3440-CCA-E	Loop-AM3440-CCA-E- G	CPU card with E1 External Clock (order two for redundancy)	
Mini Plug-in Module (Select 1 to 4 cards from list below)			
Loop-AM3440-E75	Loop-AM3440-E75- G	1-channel of E1 plug-in card w/ 75 ohm	
Loop-AM3440-E120	Loop-AM3440-E120- G	1-channel of E1 plug-in card w/ 120 ohm	
Loop-AM3440-T1	Loop-AM3440-T1- G	1-channel T1 plug-in card	
Loop-AM3440-M4E75	Loop-AM3440-M4E75- G	Mini Quad E1 plug-in card with 75 ohm	Includes a three meter conversion cable (Loop-ACC-CAB-DB25M-300-8BNCM)
Loop-AM3440-M4E120	Loop-AM3440-M4E120- G	Mini Quad E1 plug-in card with 120 ohm	Includes a three meter conversion cable (Loop-ACC-CAB-DB25M-300-4RJ48M)
Loop-AM3440-AFRE	Loop-AM3440-AFRE- G	E1 Frame Relay to ATM inter-working or Frame Relay to Frame Relay concentration plug-in card	
Loop-AM3440-AFRT	Loop-AM3440-AFRT- G	T1 Frame Relay to ATM inter-working or Frame Relay to Frame Relay concentration plug-in card	
Loop-AM3440-RT	Loop-AM3440-RT- G	2-LAN ports/32 WAN port Router/Bridge plug-in card	
Loop-AM3440-RTA	Loop-AM3440-RTA- G	2-LAN ports/64 WAN port router/bridge plug-in card	
Loop-AM3440-FOM-opt	Loop-AM3440-FOM-opt- G	Fiber Optical plug-in card	For opt option, please refer to the table below for detail information
Loop-AM3440-TS	Loop-AM3440-TS- G	3-channel Terminal Server plug-in card	Includes a one meter conversion cable (Loop-ACC-CAB-DB44M-100-2DB25F-1DB09F-TS)
Loop-AM3440-1X21	Loop-AM3440-1X21- G	1-channel X.21 plug-in card	
Loop-AM3440-1RS232	Loop-AM3440-1RS232- G	1-channel RS232 plug-in card	
Loop-AM3440-1V35	Loop-AM3440-1V35- G	1-channel V.35 plug-in card	
Loop-AM3440-1E530	Loop-AM3440-1E530- G	1-channel EIA530 plug-in card	





Loop-AM3440-Q2EM- m-Tn-x	Loop-AM3440-Q2EM- m-Tn-x-G	Quad 2 Wire E&M voice plug-in card	AM3440-CHB and AM3440-CHC only
Loop-AM3440-Q4EM- m-Tn-x	Loop-AM3440-Q4EM- m-Tn-x-G	Quad 4 Wire E&M voice plug-in card	Where m = B for normal E&M or TO (transmission only) = A for tandem operation n = 1 to 5 E&M Signaling Type = O for TO (transmission only)
Loop-AM3440-QFXS- x-pt	Loop-AM3440-QFXS- x-pt-G	Quad FXS voice plug-in card	For m , n and x option, please refer to the table below for detail information
Loop-AM3440-QFXS-M- x-pt	Loop-AM3440-QFXS-M- x-pt-G	Quad FXS with MP 16 KHz voice plug-in card	AM3440-CHB and AM3440-CHC only GS = Ground Start
Loop-AM3440-QFXS-M12- x-pt	Loop-AM3440-QFXS-M12- x-pt-G	Quad FXS with MP 12 KHz voice plug-in card	MP = Metering Pulse Transmit 12/16 KHz
Loop-AM3440-QFXS-GS- x-pt	Loop-AM3440-QFXS-GS- x-pt-G	Quad FXS with GS plug-in card	pt=power type
Loop-AM3440-QFXS-GM- x-pt	Loop-AM3440-QFXS-GM- x-pt-G	Quad FXS with GS and MP 16 KHz voice plug-in card	For x option, please refer to the table below for detail information For pt option, please refer to the table below fro detail information QFXS-GM includes all QFXS card functions
Loop-AM3440-QFXO- x	Loop-AM3440-QFXO- x-G	Quad FXO voice plug-in card	AM3440-CHB and AM3440-CHC only
Loop-AM3440-QFXO-M- x	Loop-AM3440-QFXO-M- x-G	Quad FXO with MP 16 KHz voice plug-in card	GS = Ground Start
Loop-AM3440-QFXO-M12- x	Loop-AM3440-QFXO-M12- x-G	Quad FXO with MP 12 KHz voice plug-in card	MP = Metering Pulse Receive 12/16 KHz
Loop-AM3440-QFXO-GS- x	Loop-AM3440-QFXO-GS- x-G	Quad FXO with GS plug-in card	For x option, please refer to the table below for detail information
Loop-AM3440-QFXO-GM- x	Loop-AM3440-QFXO-GM- x-G	Quad FXO with GS and MP 16 KHz voice plug-in card	For x option, please refer to the table below for detail information QFXO-GM includes all QFXO card functions
Single Slot Plug-in Module			
Not available	Loop-AM3440-3E1-cc- G	3-channel E1 plug-in card with DS0 (64K bps) SNCP protection	Order with Loop-AM3440-CHAJ or Loop-AM3440-CHCJ ONLY For cc option, please refer to the table below for detail information For controller hardware version J and software version 8.02.01 or newer versions.
Not available	Loop-AM3440-TDMoE-PPM- G	TDMoE card with 2 GbE combo interfaces and 2 Ethernet interfaces (10/100/1000BaseT) plug-in module Support G.823 Traffic	
Not available	Loop-AM3440-TDMoE-PPB- G	TDMoE card with 2 GbE combo interfaces and 2 Ethernet interfaces (10/100/1000BaseT) plug-in module Support G.823 Synchronization	Future option
Loop-AM3440-4E1-cc	Loop-AM3440-4E1-cc- G	4-channel E1 plug-in card	For cc option, please refer to the table below for detail information
Loop-AM3440-4T1	Loop-AM3440-4T1- G	4-channel T1 plug-in card	

Loop-AM3440-2GH	Loop-AM3440-2GH- G	2-channel G.SHDSL plug-in card (2 pair)	
Loop-AM3440-4GH	Loop-AM3440-4GH- G	4-channel G.SHDSL plug-in card (1 pair)	
Loop-AM3440-8CD	Loop-AM3440-8CD- G	8-channel G.703 plug-in card at 64 Kbps data rate	
Loop-AM3440-8DC	Loop-AM3440-8DC- G	8-channel dry contact plug-in card with maximum voltage 100 Vdc or 250 Vac	
Not available	Loop-AM3440-8DCB- G	8-channel dry contact type B plug-in card with maximum voltage 220 Vdc or 250 Vac	
Loop-AM3440-1C37	Loop-AM3440-1C37- G	1- channel C37.94 plug-in card	
Loop-AM3440-4C37	Loop-AM3440-4C37- G	4- channel C37.94 plug-in card	
Loop-AM3440-8RS232-RJ	Loop-AM3440-8RS232-RJ- G	8-port RS232 plug-in card with X.50 subrate multiplexing scheme and X.54 encoding, with 8 RJ48 connectors for 8 RS232 Async ports	
Loop-AM3440-8RS232-DB	Loop-AM3440-8RS232-DB- G	8-port RS232 plug-in card with X.50 subrate multiplexing scheme and X.54 encoding, with 2 RJ48 connectors and 2 DB44 connectors for Async and Sync ports	Two conversion cables are included (DB44 connector to two DB25 and one DB9 connector; (Loop-ACC-CAB-DB44M-100-2DB25F-1DB09F-DB).
Not available	Loop-AM3440-8DBRA-RJ- G	8-channel data bridge plug-in card, with 8 RJ48 connectors for 8 data bridge Async ports	Future option
Not available	Loop-AM3440-8DBRA-DB- G	8-channel data bridge plug-in card, with 2 RJ48 connectors and 2DB44 connectors for 8 data bridge Async ports	Two conversion cables are included (DB44 connector to two DB25 and one DB9 connector; (Loop-ACC-CAB-DB44M-100-2DB25F-1DB09F-DB). Future option
Loop-AM3440-RTB	Loop-AM3440-RTB- G	8-LAN ports/64 WAN ports router/bridge plug-in card	For controller hardware version F and software version 6.05.02 or newer versions.
Not available	Loop-AM3440-CONF- G	Conference plug-in card with two RS232 data ports, two FXS ports and two E&M ports	For controller hardware version F and software version 7.05.01 or newer versions.
Loop-AM3440-8EM-x	Loop-AM3440-8EM-x- G	8-channel 2W/4W E&M plug-in card with 8 RJ45	For x option, please refer to the table below for detail information
Loop-AM3440-12FXS- sn-pt	Loop-AM3440-12FXS- sn-pt-G	12-channel FXS plug-in card with 600/900 Impedance, Battery Reverse, Loop Start and PLAR. Without Ground Start and Metering Pulse. Used with 12 RJ11.	12FXS-GMP includes all FXS card functions For sn option, please refer to the table below for detail information
Loop-AM3440-12FXS-P- sn-pt	Loop-AM3440-12FXS-P- sn-pt-G	12-channel FXS plug-in card with 600/900 Impedance, Battery Reverse, Loop Start, PLAR and [PLAR bit programmable]. Without Ground Start and Metering Pulse. Used with 12 RJ11.	pt= power type. For pt option, please refer to the table below for detail information
Loop-AM3440-12FXS-M- pt	Loop-AM3440-12FXS-M- pt-G	12-channel FXS plug-in card with 600/900 Impedance, Battery Reverse, Loop Start, PLAR and [Metering Pulse]. Used with 12 RJ11.	The IEEE1613 standard applies to AM3440-CHA only
Loop-AM3440-12FXS-MPP- pt	Loop-AM3440-12FXS-MPP- pt-G	12-channel FXS plug-in card with 600/900 Impedance, Battery Reverse, Loop Start, PLAR, [PLAR bit programmable] and [Metering Pulse]. Used with 12 RJ11.	

Loop-AM3440-12FXS-GS-pt	Loop-AM3440-12FXS-GS-pt-G	12-channel FXS plug-in card with 600/900 Impedance, Battery Reverse, Loop Start, PLAR and [Ground Start]. Used with 12 RJ11.	
Loop-AM3440-12FXS-GM-sn-pt	Loop-AM3440-12FXS-GM-sn-pt-G	12-channel FXS plug-in card with 600/900 Impedance, Battery Reverse, Loop Start, PLAR, [Ground Start] and [Metering Pulse]. Used with 12 RJ11.	
Loop-AM3440-12FXS-GMP-pt	Loop-AM3440-12FXS-GMP-pt-G	12-channel FXS plug-in card with 600/900 Impedance, Battery Reverse, Loop Start, PLAR, [PLAR bit programmable], [Ground Start] and [Metering Pulse]. Used with 12 RJ11.	
Loop-AM3440-12FXO	Loop-AM3440-12FXO-G	12-channel FXO plug-in card with 600/900 Impedance, Battery Reverse and Loop Start. Without Ground Start and Metering Pulse. Used with 12 RJ11.	12FXO-GM includes all FXO card functions
Loop-AM3440-12FXO-M	Loop-AM3440-12FXO-M-G	12-channel FXO plug-in card with 600/900 Impedance, Battery Reverse, Loop Start and [Metering Pulse]. Used with 12 RJ11.	
Loop-AM3440-12FXO-GS	Loop-AM3440-12FXO-GS-G	12-channel FXO plug-in card with 600/900 Impedance, Battery Reverse, Loop Start and [Ground Start]. Used with 12 RJ11.	
Loop-AM3440-12FXO-GM	Loop-AM3440-12FXO-GM-G	12-channel FXO plug-in card with 600/900 Impedance, Battery Reverse, Loop Start, [Ground Start] and [Metering Pulse]. Used with 12 RJ11.	
Loop-AM3440-12MAG-1G-x	Loop-AM3440-12MAG-1G-x-G	12-channel Magneto plug-in module w/ L1. GND	12MAG-1G2 includes all function of MAG cards. For x option, please refer to the table below for detail information
Loop-AM3440-12MAG-12-x	Loop-AM3440-12MAG-12-x-G	12-channel Magneto plug-in module w/ L1, L2	
Loop-AM3440-12MAG-1G2-x	Loop-AM3440-12MAG-1G2-x-G	12-channel Magneto plug-in module w/ L1, L2, and L1. GND	
Dual Slot Plug-in Module			
Loop-AM3440-6X21A	Loop-AM3440-6X21A-G	6-channel X.21/V.11 plug-in card with DB15S connector	
Loop-AM3440-6V35A	Loop-AM3440-6V35A-G	6-channel V.35 plug-in card with DB25S connector via conversion cable to M34 (2M bits per channel)	
Loop-AM3440-6V36A	Loop-AM3440-6V36A-G	6-channel V.36 plug-in card with DB25 connector via conversion cable to DB37	
Loop-AM3440-6E530A	Loop-AM3440-6E530A-G	6-channel EIA530 plug-in card with DB25 connector	
Loop-AM3440-6RS449A	Loop-AM3440-6RS449A-G	6-channel EIA530/RS449 plug-in card with DB25 connector via conversion cable to DB37	
Loop-AM3440-5RS232	Loop-AM3440-5RS232-G	5-channel RS232 plug-in card with X.50 substrate plug-in module	

Loop-AM3440-2GHL	Not available	2-channel G.SHDSL plug-in card with line power source (140 Vdc, 110mA), (2 pair)	For AM3440-CHA only Factory installed option available with -48 Vdc, -125Vdc powered chassis only. With line power, takes 2 DTE slots per card. Fan tray required.
Loop-AM3440-4GHL	Not available	4-channel G.SHDSL plug-in card with line power source (190 Vdc, 60mA), (1 pair)	For AM3440-CHA only Factory installed option available with -48 Vdc, -125Vdc powered chassis only. With line power, takes 2 DTE slots per card. Fan tray required.
Loop-AM3440-24FXS- sn-pt	Loop-AM3440-24FXS- sn-pt-G	24-channel FXS plug-in card with 600/900 Impedance, Battery Reverse, Loop Start and PLAR. Without Ground Start and Metering Pulse	<p>24FXS-GMP includes all FXS card functions.</p> <p>pt= power type</p> <p>For sn option, please refer to the table below for detail information</p> <p>For pt option, please refer to the table below for detail information</p> <p>The IEEE1613 standard applies to AM3440-CHA only</p>
Loop-AM3440-24FXS-P- sn-pt	Loop-AM3440-24FXS-P- sn-pt-G	24-channel FXS plug-in card with 600/900 Impedance, Battery Reverse, Loop Start, PLAR and [PLAR bit programmable]. Without Ground Start and Metering Pulse	
Loop-AM3440-24FXS-M- pt	Loop-AM3440-24FXS-M- pt-G	24-channel FXS plug-in card with 600/900 Impedance, Battery Reverse, Loop Start, PLAR and [Metering Pulse].	
Loop-AM3440-24FXS-MPP- pt	Loop-AM3440-24FXS-MPP- pt-G	24-channel FXS plug-in card with 600/900 Impedance, Battery Reverse, Loop Start, PLAR, [PLAR bit programmable] and [Metering Pulse].	
Loop-AM3440-24FXS-GS- pt	Loop-AM3440-24FXS-GS- pt-G	24-channel FXS plug-in card with 600/900 Impedance, Battery Reverse, Loop Start, PLAR and [Ground Start].	
Loop-AM3440-24FXS-GM- pt	Loop-AM3440-24FXS-GM- pt-G	24-channel FXS plug-in card e with 600/900 Impedance, Battery Reverse, Loop Start, PLAR, [Ground Start] and [Metering Pulse].	
Loop-AM3440-24FXS-GMP- pt	Loop-AM3440-24FXS-GMP- pt-G	24-channel FXS plug-in card with 600/900 Impedance, Battery Reverse, Loop Start, PLAR, [PLAR bit programmable], [Ground Start] and [Metering Pulse].	
Loop-AM3440-24FXO	Loop-AM3440-24FXO- G	24-channel FXO plug-in card with 600/900 Impedance, Battery Reverse and Loop Start. Without Ground Start and [Metering Pulse].	
Loop-AM3440-24FXO-M	Loop-AM3440-24FXO-M- G	24-channel FXO plug-in card with 600/900 Impedance, Battery Reverse, Loop Start and [Metering Pulse].	

Loop-AM3440-24FXO-GS	Loop-AM3440-24FXO-GS- G	24-channel FXO plug-in card with 600/900 Impedance, Battery Reverse, Loop Start and [Ground Start].	
Loop-AM3440-24FXO-GM	Loop-AM3440-24FXO-GM- G	24-channel FXO plug-in card with 600/900 Impedance, Battery Reverse, Loop Start, [Ground Start] and [Metering Pulse].	

Accessories			
Power Module			
Loop-AM3440-SD	Loop-AM3440-SD- G	Single -48 Vdc (-36 to -75 Vdc) Power Module (100W)	For AM3440-CHA only For shared redundancy, order 2 single DC.
Loop-AM3440-S5	Loop-AM3440-S5- G	Single -48 Vdc (-36 to -75 Vdc) Power Module (150W)	
Loop-AM3440-SD125	Loop-AM3440-SD125- G	Single -125 Vdc (-40 to -150 Vdc) Power Module (100W)	For AM3440-CHA only For shared redundancy, order 2 single DC If the user orders -125 Vdc power module, the maximum number of cards allowed in slot 1 to 12 is: <ul style="list-style-type: none"> • Four 12-channel FXS • Nine 12-channel Magneto • Eleven 8-channel 2W/4W E&M • Two 4-channel G. SHDSL (1 pair) with line power • Three 2-channel G. SHDSL (2 pairs) with line power • Two 24-channel FXS There are no limitations for other plug-in cards in slot 1 to 12. There are no limitations for any plug-in cards in slot A to D. For power consumption details, please refer to AM3440-A User's Manual.
Loop-AM3440-S524	Loop-AM3440-S524- G	Single -24 Vdc (-18 to -36 Vdc) Power Module (150W)	For AM3440-CHA only Cannot be used with MAG card.
Loop-AM3440-SDB	Loop-AM3440-SDB- G	Single -48 Vdc (-36 to -75 Vdc) Power Module (100W)	For AM3440-CHB/CHC For shared redundancy, order 2 single DC.
Loop-AM3440-SD24W150	Loop-AM3440-SD24W150- G	Single -24 Vdc (-18 to -36 Vdc) Power Module (150W)	For AM3440-CHB/CHC For shared redundancy, order 2 single DC. Future Option
Loop-AM3440-SAB	Loop-AM3440-SAB- G	Single AC plug-in power supply (100 to 240 Vac, 50/60 Hz)	For AM3440-CHB/CHC For AC choose an appropriate power cord
Mounting Ear			
19"/23" ear mounts	A pair of 19"/23" ear mounts is supplied as part of standard package. Note: For other sizes, please contact your nearest Loop sales representative.		
User's Manual			
Loop-AM3440-UM	User's Manual (optional, paper copy). A CD version of the manual is already included as standard equipment.		For AM3440-CHA only
Loop-AM3440-UMB	User's Manual (optional, paper copy). A CD version of the manual is already included as standard equipment.		For AM3440-CHB only
Loop-AM3440-UMC	User's Manual (optional, paper copy). A CD version of the manual is already included as standard equipment.		For AM3440-CHC only
Power Cord (All power cord are RoHS compliant)			
Loop-ACC-PC-USA	AC power cord for Taiwan/America		
Loop-ACC-PC-EU	AC power cord for Europe		
Loop-ACC-PC-UK	AC power cord for UK		
Loop-ACC-PC-AUS	AC power cord for Australia		
Loop-ACC-PC-CH	AC power cord for China		

Power Adaptor (All power adaptor are RoHS compliant)			
Loop-ACC-APA-240- G	240 Watt, AC (100 to 120 Vac, 5.0A/200 to 240 Vac, 2.5A auto sensing) to DC (-48 Vdc, 5A) adaptor for USA		
Loop-ACC-APE-240- G	240 Watt, AC (100 to 120 Vac, 5.0A/200 to 240 Vac, 2.5A auto sensing) to DC (-48 Vdc, 5A) adaptor for Europe		
Loop-ACC-APU-240- G	240 Watt, AC (100 to 120 Vac, 5.0A/200 to 240 Vac, 2.5A auto sensing) to DC (-48 Vdc, 5A) adaptor for UK		
Fan Tray			
Loop-AM3440-FAN	Loop-AM3440-FAN- G	Fan tray	For AM3440-CHA only Power supplied from rear of chassis. If total power consumption of device and cards is more than 60 Watts, an additional fan tray is required. For power consumption and fan tray plan, please refer to AM3440-A User's Manual.
FXO Box			
Loop-AM3440-FXO BOX	Support FXO Interface Battery Feed		
External LCD			
Loop-AM3440-LCD	Loop-AM3440-LCD- G	External LCD and Keypad	only cover selected plug-in cards only, contact your nearest Loop sales representative for detail
Software			
Loop-AM3440-ERING	ULSR-PDH Ring software		Used with 4E1, M4E75, M4E120 and FOM
Loop-AM3440-TRING	ULSR-PDH Ring software		Used with 4T1
Conversion Cables (All conversion cables are RoHS compliant)			
Loop-ACC-CAB-DB25M-100-8BNCM	DB25/Male to eight BNC/Male cable; Length: 100 cm		Used in Loop-AM3440-M4E75 plug-in card
Loop-ACC-CAB-DB25M-300-8BNCM	DB25/Male to eight BNC/Male cable; Length: 300 cm		Used in Loop-AM3440-M4E75 plug-in card
Loop-ACC-CAB-DB25M-100-4RJ48M	DB25/Male to four RJ48C/Male cable; Length: 100 cm		Used in Loop-AM3440-M4E120 plug-in card
Loop-ACC-CAB-DB25M-300-4RJ48M	DB25/Male to four RJ48C/Male cable; Length: 300 cm		Used in Loop-AM3440-M4E120 plug-in card
Loop-ACC-CAB-DB44M-100-2DB25F-1DB09F-DB	DSUB-44 pin/Male to two DSUB-25 pin/Female- one DSBU-9 pin/Female (8P8C) plug, Length:100cm		Used in Loop-AM3440-8RS232-DB, Loop-AM3440-8DBRA-DB plug-in card
Loop-ACC-CAB-DB44M-100-2DB25F-1DB09F-TS	DSUB-44 pin/Male to two DSUB-25 pin/Female- one DSBU-9 pin/Female (8P8C) plug, Length:100cm		Used in Loop-AM3440-TS plug-in card
Loop-ACC-CAB-DB25M-30-1M34F	DSUB-25pin/Male to M34/Female V.35 Conversion cable Length: 30 cm		Used in Loop-AM3440-6V35A and Loop-AM3440-1V35 plug-in cards
Loop-ACC-CAB-DB25M-30-1DB37F	DSUB-25pin/Male to DSUB-37/Female RS449 Conversion cable Length: 30 cm		Used in Loop-AM3440-6V36A and Loop-AM3440-6R449A plug-in cards
Y-Box (All Y-Box are RoHS compliant)			
Loop-VV-B- G	1 for 1 protection Y-Box with BNC connectors (4-E1)		Used with 4E1
Loop-VV-R- G	1 for 1 protection Y-Box with RJ48C connectors (16-E1)		Used with 4E1
Loop-VV-T- G	1 for 1 protection Y-Box with RJ48C connectors (16-T1)		Used with 4T1
Blank Panels (All blank panels are RoHS compliant)			
30.000333.A00- G	Blank Panel for Power Supply Slot (flat)		For AM3440-CHA only
30.001257.A00- G	Blank Panel for Power Supply Slot (flat)		For use in AM3440-CHB/CHC
30.000349.A00- G	Blank Panel for Controller Slot (flat)		For use in any AM3440 chassis
30.000335.A00- G	Blank Panel for mini Slot A-D (flat)		For use in AM3440-CHA/CHB/CHC
30.000331.A00- G	Blank Panel for Slot 1-12 (flat)		For use in AM3440-CHA/CHB/CHC
30.001028.A00- G	Blank Panel for Power Slot (u-shape)		For AM3440-CHA only
30.001029.A00- G	Blank Panel for Controller (u-shape)		For use in any AM3440 chassis
30.001030.A00- G	Blank Panel for mini Slot A-D (u-shape)		For use in AM3440-CHA/CHB/CHC
30.001027.A00- G	Blank Panel for Slot 1-12 (u-shape)		For use in AM3440-CHA/CHB/CHC
SFP Optical Modules			
Please place your order by using 5 letters in the SFP optical module table below.			

For 4E1 and 3E1cards

■ Where **cc** is used to select connector:

cc =	Description	Note
RJ	RJ48C connector	
BNC	BNC connector	

For FOM card

■ Where **opt** is used to select optical module type (All optical modules are RoHS compliant):

opt =	Description	Note
SAA	Single optical module with dual uni-directional fiber, 1310 nm, SC optical connector, 30 km reach (19dB) - S1.1	Use dual fiber Units delivered ITU-T G.957 application code
SBB	Single optical module with dual uni-directional fiber, 1310 nm, SC optical connector, 50 km reach (30dB) - L1.1	
SCC	Single optical module with dual uni-directional fiber, 1310 nm, FC optical connector, 30 km reach (20dB) - S1.1	
SDD	Single optical module with dual uni-directional fiber, 1550 nm, SC optical connector, 20 km reach (12dB) - S1.2	
SEE	Single optical module with dual uni-directional fiber, 1550 nm, SC optical connector, 100 km reach (30dB) - L1.2	
SSM	Single optical module with single bi-directional fiber (master), 1310 nm transmit and 1550 receive, SC optical connector, 30 km reach (20dB) - S1.1/S1.2	1310 nm from master to slave Order SSM to use with SSS Use 1 fiber ITU-T G.957 application code
SSS	Single optical module with single bi-directional fiber (slave), 1310 nm receive and 1550 transmit, SC optical connector, 30 km reach (20dB) - S1.1/S1.2	1550 nm from slave to master Order SSS to use with SSM Use 1 fiber ITU-T G.957 application code

Note: For other special optical modules, please contact your nearest Loop sales representative.

For Quad 2W/4W E&M card:

■ Where **m** is used to select QEM card signaling side (must select one):

m =	Description	Note
B	B (carrier side) connects to A side.	
A	A (exchange side) connects to B side. A side M lead to B side M lead, A side E lead to B side E lead.	

■ Where **n** is used to select QEM card signaling type (must select one):

n =	Description	Note
0	For voice transmission only.	Circuit Type doesn't matter.
1	Type I (Original) E&M Signaling Circuit	M lead provides discharge for the A side.
2	Type II Circuit. This design attempts to reduce ground noise by adding two leads: SB (Signal to Battery) and SG (Signal to Ground)	Reduced ground noise. Ground current is eliminated at the cost of two more wires per circuit.
3	Type III Circuit. The SG lead serves as a discharge for the M lead. Reduces delay caused by combination of (a) low current electronic detectors, and (b) long runs of the E and M leads.	Type III is rare because ground currents on the E return would cause noise
4	Type IV Circuit. Based on the Type 2 circuit. This E&M circuit provides symmetry.	
5	Type V Circuit. For applications where ground noise is not an issue. Based on the Type 2 circuit.	

For voice card(8-channel 2W/4W E&M, Quad 2W/4W E&M and QFXS/QFXO):

■ Where **x** is used to select all of voice card signaling bits. If this option is not required, omit the **x** field in the ordering code.

x =	Description	Note
8EM	E	Follows ETSI signaling bits
	A	Follows ANSI signaling bits
	R	Reverse for ON-HOOK and OFF-HOOK signaling bits exchange
	S	Follows customer's special bit or function assignment
	AR	Follows ANSI signaling bits and reverse bit
QEM	E	Follows ETSI signaling bits
	A	Follows ANSI signaling bits
	S	Follows customer's special bits assignment
QFXS/QFXO	A	Follows ANSI signaling bits
	S	Follows customer's special bits assignment
	T	Trunk condition OFF-HOOK
	AT	Follows ANSI signaling bits w/ trunk condition OFF-HOOK
	ST	Follows customer's special bits assignment w/ trunk condition OFF-HOOK

Jumper selectable for all channels

■ **A** and **S** are for QFXS/QFXO

■ **T, AT, ST** are for QFXO only

Note:

1. For **S** (customer's special bit), please contact your nearest Loop sales representative.
2. If **x** is not selected from table above, the default setting for signaling bits is ETSI and for trunk condition is ON-HOOK.

For 12/24-channel FXS card:

■ Where **sn** is used to select special function. If this option is not required, omit the **sn** field in the ordering code.

sn =	Description	Note
S1	FXS Loop Feed = -48 Vdc with 35 mA current limit	
S4	Remove alarm tone	
S5	Double ring tone transmit	

Note: For **sn** (special function), please contact your nearest Loop sales representative.

■ Where **pt** is used to select the following functions.

pt=	Description	Note
PWR	complied with -48 Vdc(SD, S5, SDB), -125Vdc(SD125) and AC (SAB) power modules	
PWRIE1613	complied with IEEE1613 standard, and with -48 Vdc(S5) power module	For AM3440-CHA only
24	complied used with -24 Vdc(S524) power module	

For QFXS card:

Where **pt** is used to select the following functions.

pt=	Description	Note
PWR	complied with -48 Vdc(SDB) and AC (SAB) power modules	
24	complied used with -24 Vdc(SD24W150) power module	Future Option

For Magneto Card:

■ Where **x** is used to select version type:

x=	Description	Note
16	16 Hz ring generator	20 Hz is the general setting for all MAG cards. For special settings (16,25,50), please specify your need by filling in the x option.
20	20 Hz ring generator	
25	25 Hz ring generator	
50	50 Hz ring generator	

For TDMoE:

SFP Optical/Electrical Module Plug-in Table

1.25G (mini GBIC) Dual Fiber Commercial (0 to 70°C)	MTAFW	multi-mode optical module with dual uni-directional fiber, 1.25G, 850nm, 550m, LC connector w/o DDM, 1000Base-SX	<ul style="list-style-type: none"> ▪ Use 2 fibers for all SFP optical modules ▪ All 1.25G optical module downgrading to 622Mbps data rate will be workable
	MTAFD	Single-mode optical module with dual uni-directional fiber, 1.25G, 850nm, 550m, LC connector with DDM, 1000Base-SX	
	MTBTD	Single-mode optical module with dual uni-directional fiber, 1.25G, 1310nm, 2Km, LC connector with DDM, 1000Base-SX+	
	MTBTW	multi-mode optical module with dual uni-directional fiber, 1.25G, 1310nm, 2Km, LC connector w/o DDM, 1000Base-SX+	
	PTB2W	single-mode optical module with dual uni-directional fiber, 1.25G, 1310nm, 20Km, LC connector w/o DDM, 1000Base-LX	
	PTB4W	single-mode optical module with dual uni-directional fiber, 1.25G, 1310nm, 40Km, LC connector w/o DDM, 1000Base-LHX	
	PTC5W	single-mode optical module with dual uni-directional fiber, 1.25G, 1550nm, 50Km, LC connector w/o DDM, 1000Base-XD	
	PTC6W	single-mode optical module with dual uni-directional fiber, 1.25G, 1550nm, 60Km, LC connector w/o DDM, 1000Base-XD	
	PTC8W	single-mode optical module with dual uni-directional fiber, 1.25G, 1550nm, 80Km, LC connector w/o DDM, 1000-Base-ZX	
	PTC9W	single-mode optical module with dual uni-directional fiber, 1.25G, 1550nm, 90Km, LC connector w/o DDM, 1000Base-ZY	
	PTCVW	single-mode optical module with dual uni-directional fiber, 1.25G, 1550nm, 110Km, LC connector w/o DDM, , 1000Base-APD	
	PTCXW	single-mode optical module with dual uni-directional fiber, 1.25G, 1550nm, 120Km, LC connector w/o DDM1000Base-APD	
	PTB1D	single-mode optical module with dual uni-directional fiber, 1.25G, 1310nm, 10Km, LC connector with DDM, 1000Base-LX	
	PTB3D	single-mode optical module with dual uni-directional fiber, 1.25G, 1310nm, 30Km, LC connector with DDM, 1000Base-LHX	
	PTB4D	single-mode optical module with dual uni-directional fiber, 1.25G, 1310nm, 40Km, LC connector with DDM, 1000Base-LHX	
	PTC5D	single-mode optical module with dual uni-directional fiber, 1.25G, 1550nm, 50Km, LC connector with DDM, 1000Base-XD	
	PTC6D	single-mode optical module with dual uni-directional fiber, 1.25G, 1550nm, 60Km, LC connector with DDM, 1000Base-XD	
	PTC8D	single-mode optical module with dual uni-directional fiber, 1.25G, 1550nm, 80Km, LC connector with DDM, 1000Base-ZX	
	PTC9D	single-mode optical module, with dual unidirectional fiber, 1.25G, 1550nm, 90Km, LC connector with DDM	
	PTCVD	single-mode optical module with dual uni-directional fiber, 1.25G, 1550nm, 110Km, LC connector with DDM, 1000Base-APD	
PTCXD	single-mode optical module with dual uni-directional fiber, 1.25G, 1550nm, 120Km, LC connector with DDM, DDM1000Base-APD		
622M-1.25G (mini GBIC) Dual Fiber Commercial (0 to 70°C)	PKB1W	single-mode optical module with dual uni-directional fiber, 622Mbps~1.25G, 1310nm, 10Km, LC connector w/o DDM, 1000Base-LX	

1.25G (mini GBIC) Bi-directional Single Fiber Commercial (0 to 70°C)	PTD1W	Single mode optical module with single bi-directional fiber, 1.25G, Tx 1310 nm / Rx 1550 nm, 10Km, LC connector w/o DDM, GbE/1X fiber channel	<ul style="list-style-type: none"> ▪ 1310 nm from master to slave ▪ Order PTD1W to use with PTE1W ▪ Use 1 fiber
	PTE1W	Single mode optical module with single bi-directional fiber, 1.25G, Tx 1550 nm / Rx 1310 nm, 10Km, LC connector w/o DDM, GbE/1X fiber channel	<ul style="list-style-type: none"> ▪ 1550 nm from slave to master ▪ Order PTE1W to use with PTD1W ▪ Use 1 fiber
	PTD2W	Single mode optical module with single bi-directional fiber, 1.25G, Tx 1310 nm / Rx 1550 nm, 20Km, LC connector w/o DDM, GbE/1X fiber channel	<ul style="list-style-type: none"> ▪ 1310 nm from master to slave ▪ Order PTD2W to use with PTE2W ▪ Use 1 fiber

PTE2W	Single mode optical module with single bi-directional fiber, 1.25G, Tx 1550 nm / Rx 1310 nm, 20Km, LC connector w/o DDM, GbE/1X fiber channel	<ul style="list-style-type: none"> ▪ 1550 nm from slave to master ▪ Order PTE2W to use with PTD2W ▪ Use 1 fiber
PTD4W	Single mode optical module with single bi-directional fiber, 1.25G, Tx 1310 nm / Rx 1550 nm, 40Km, LC connector w/o DDM, GbE/1X fiber channel	<ul style="list-style-type: none"> ▪ 1310 nm from master to slave ▪ Order PTD4W to use with PTE4W ▪ Use 1 fiber
PTE4W	Single mode optical module with single bi-directional fiber, 1.25G, Tx 1550 nm / Rx 1310 nm, 40Km, LC connector w/o DDM, GbE/1X fiber channel	<ul style="list-style-type: none"> ▪ 1550 nm from slave to master ▪ Order PTE4W to use with PTD4W ▪ Use 1 fiber
PTD6W	Single mode optical module with single bi-directional fiber, 1.25G, Tx 1310 nm / Rx 1550 nm, 60Km, LC connector w/o DDM, GbE/1X fiber channel	<ul style="list-style-type: none"> ▪ 1310 nm from master to slave ▪ Order PTD6W to use with PTE6W ▪ Use 1 fiber
PTE6W	Single mode optical module with single bi-directional fiber, 1.25G, Tx 1550 nm / Rx 1310 nm, 60Km, LC connector w/o DDM, GbE/1X fiber channel	<ul style="list-style-type: none"> ▪ 1550 nm from slave to master ▪ Order PTE6W to use with PTD6W ▪ Use 1 fiber
PTD1D	Single mode optical module with single bi-directional fiber, 1.25G, Tx 1310 nm / Rx 1550 nm, 10Km, LC connector with DDM, GbE/1X fiber channel	<ul style="list-style-type: none"> ▪ 1310 nm from master to slave ▪ Order PTD1D to use with PTE1D ▪ Use 1 fiber
PTE1D	Single mode optical module with single bi-directional fiber, 1.25G, Tx 1550 nm / Rx 1310 nm, 10Km, LC connector with DDM, GbE/1X fiber channel	<ul style="list-style-type: none"> ▪ 1550 nm from slave to master ▪ Order PTE1D to use with PTD1D ▪ Use 1 fiber
PTD2D	Single mode optical module with single bi-directional fiber, 1.25G, Tx 1310 nm / Rx 1550 nm, 20Km, LC connector with DDM, GbE/1X fiber channel	<ul style="list-style-type: none"> ▪ 1310 nm from master to slave ▪ Order PTD2D to use with PTE2D ▪ Use 1 fiber
PTE2D	Single mode optical module with single bi-directional fiber, 1.25G, Tx 1550 nm / Rx 1310 nm, 20Km, LC connector with DDM, GbE/1X fiber channel	<ul style="list-style-type: none"> ▪ 1550 nm from slave to master ▪ Order PTE2D to use with PTD2D ▪ Use 1 fiber
PTD4D	Single mode optical module with single bi-directional fiber, 1.25G, Tx 1310 nm / Rx 1550 nm, 40Km, LC connector with DDM, GbE/1X fiber channel	<ul style="list-style-type: none"> ▪ 1310 nm from master to slave ▪ Order PTD4D to use with PTE4D ▪ Use 1 fiber
PTE4D	Single mode optical module with single bi-directional fiber, 1.25G, Tx 1550 nm / Rx 1310 nm, 40Km, LC connector with DDM, GbE/1X fiber channel	<ul style="list-style-type: none"> ▪ 1550 nm from slave to master ▪ Order PTE4D to use with PTD4D ▪ Use 1 fiber
PTD6D	Single mode optical module with single bi-directional fiber, 1.25G, Tx 1310 nm / Rx 1550 nm, 60Km, LC connector with DDM, GbE/1X fiber channel	<ul style="list-style-type: none"> ▪ 1310 nm from master to slave ▪ Order PTD6D to use with PTE6D ▪ Use 1 fiber
PTE6D	Single mode optical module with single bi-directional fiber, 1.25G, Tx 1550 nm / Rx 1310 nm, 60Km, LC connector with DDM, GbE/1X fiber channel	<ul style="list-style-type: none"> ▪ 1550 nm from slave to master ▪ Order PTE6D to use with PTD6D ▪ Use 1 fiber
PTD8D	Single mode optical module with single bi-directional fiber, 1.25G, Tx 1310 nm / Rx 1550 nm, 80Km, LC connector with DDM, GbE/1X fiber channel	<ul style="list-style-type: none"> ▪ 1310 nm from master to slave ▪ Order PTD8D to use with PTE8D ▪ Use 1 fiber
PTE8D	Single mode optical module with single bi-directional fiber, 1.25G, Tx 1550 nm / Rx 1310 nm, 80Km, LC connector with DDM, GbE/1X fiber channel	<ul style="list-style-type: none"> ▪ 1550 nm from slave to master ▪ Order PTE8D to use with PTD8D ▪ Use 1 fiber

The list shown below is the discontinued chassis and plug in cards. For detail info, please contact your nearest Loop sales representative.

Model	Description	Note
Loop-AM3440-CH	32 Mb/s cross-connect capacity backplane t without CPU, power and plug-in cards	AM3440-CH type Chassis
Loop-AM3440-6U	6-channel IDSL plug-in card	
Loop-AM3440-10U	10-channel IDSL plug-in card	
Loop-AM3440-3H	3-channel MDSL plug-in card (2Mb for 3-channel)	
Loop-AM3440-3HA	3-channel MDSL plug-in card for	AM3440-A/B/C only
Loop-AM3440-3HAL	3-channel 6Mbits MDSL plug-in module with line power source	AM3440-A only Factory installed option available with -48 Vdc powered chassis only.
Loop-AM3440-ODP	8-channel OCU-DP plug-in card	AM3440-A/B/C only

Example 1:

Loop-AM3440-CHA, Loop-AM3440-CCA-E, Loop-AM3440-S5, Loop-AM3440-4E1-RJ, Loop-AM3440-8RS232

Loop-AM3440-FAN:

For 3440-A type chassis with a CPU card(E1 external clock), a single -48 Vdc 150W power module, 4-channel E1 interface with RJ48C connectors, one 8RS232 plug-in module and fan tray.

Example 2:

Loop-AM3440-CHB, Loop-AM3440-CCA-E, Loop-AM3440-SDB, Loop-AM3440-M4E75, Loop-AM3440-8CD:

For 3440-B type chassis with a CPU card(E1 external clock), a single -48 Vdc 100W power module, one Mini Quad E1 interface with 75 ohm and one 8-channel G.703 interface at 64 Kbps data rate.

Example 3:

Loop-AM3440-CHC, Loop-AM3440-CCA-E, Loop-AM3440-SDB, Loop-AM3440-M4E120, Loop-AM3440-2GH:

For 3440-C type chassis with a CPU card(E1 external clock), a single -48 Vdc 100W power module, one Mini Quad E1 interface with 120 ohm and one 2-channel G.SHDSL plug-in module (2 pair).

LOOP-AM3440 Access DCS-MUX Product Specifications

Network Line Interface - T1

Line Rate	1.544 Mbps \pm 32ppm	Output Signal	DSX1w/0, -7.5, -15 dB LBO
Line Code	AMI or B8ZS	Framing	D4/ESF (selectable)
Input Signal	DSX-1 0 dB to -30 dB w/ALBO	Connector	RJ48C

Network Line Interface - E1

Line Rate	2.048 Mbps \pm 50 ppm	Framing	ITU G.704
Line Code	AMI or HDB3	Connector	BNC/RJ48C
Input Signal	ITU G.703	Electrical	75 ohm Coax/120 ohm twisted pair
Output Signal	ITU G.703	Jitter	ITU G.823

Network Line Interface - Mini 4E1

Line Rate	2.048 Mbps \pm 50 ppm	Framing	ITU G.704
Line Code	AMI or HDB3	Connector	DB25S
Input Signal	ITU G.703	Electrical	75 ohm Coax/120 ohm twisted pair
Output Signal	ITU G.703	Jitter	ITU G.823

Network Line Interface - 3E1*

Line Rate	2.048 Mbps \pm 50 ppm	Framing	ITU G.704
Line Code	AMI or HDB3	Connector	BNC/RJ48C
Input Signal	ITU G.703	Electrical	75 ohm Coax/120 ohm twisted pair
Output Signal	ITU G.703	Jitter	ITU G.823
Function	Support DS0-SNCP		

Network Line Interface - 4E1

Line Rate	2.048 Mbps \pm 50 ppm	Framing	ITU G.704
Line Code	AMI or HDB3	Connector	BNC/RJ48C
Input Signal	ITU G.703	Electrical	75 ohm Coax/120 ohm twisted pair
Output Signal	ITU G.703	Jitter	ITU G.823

Network Line Interface - 4T1

Line Rate	1.544 Mbps \pm 32 ppm	Output Signal	DSX1w/0, -7.5, -15 dB LBO
Line Code	AMI or B8ZS	Framing	D4/ESF (selectable)
Input Signal	DSX-1 0 dB to -30 dB w/ALBO	Connector	RJ48C

ATM Frame Relay Network Line Interface

Supporting Network Interworking (FRF.5) and service interworking (FRF.8).

Network Interface:

- T1 Module: *T1 ATM UNI*
FR (n x 64 Kbps, n=1 to 24)
- E1 Module: *E1 ATM UNI*
FR (n x 64 Kbps, n= 1 to 31)

Up to 31 logical FR channels can be concentrated/ de-concentrated to FR or ATM.

Service Ports:

- T1/FT1 interface: *n x 64 Kbps, n=1 to 24*
- E1/FE1 interface: *n x 64 Kbps, n= 1 to 31*

Support HDLC to FR

Support HDLC to ATM

Supporting FR to FR multiplexing.

Support up to 128 DLCIs for total of 31 FR interfaces.

Support up to 128 VCs.

Peak cell rate on DLCI basis.

Manufacturing disable/enable ATM scrambling for internal testing (E1 ATM only).

AAL0 and AAL5 are supported in the ATM adaptation layer.

Support VBR service.

ANSI and ITU FR management protocols are supported.

Flash memory software download through RS485.

Only the PVC type of ATM/FR service is supported.

Router Interface

Number of ports	2 LAN ports, Max. 32 WAN ports
Physical Interface	10 BaseT x 1, 10/100 BaseT x 1
Connector	RJ45
Routing protocol	RIP-I, RIP-II
Data Rates	Channelized N x 64 Kbps up to T1/E1 capacity
Supporting Protocols	TCP/IP, PPP, HDLC

Router-A Interface

Number of ports	2 LAN ports, Max. 64 WAN ports, Each WAN port has data rate n x 64K bps, 1 ≤ n ≤ 32 (≤ 4Mbps for total of all 64 WAN ports)
Physical Interface	10/100 BaseT x 2
Connector	RJ45
Routing protocol	RIP-I, RIP-II, OSPF, Static
Supporting Protocols	PPP (IPCP/BCP), MLPPP, HDLC, Frame Relay, and Cisco compatible HDLC, NAT/NAPT, DHCP
Diagnostic	Ping, Trace route
QoS	Rate limit

Router-B Interface

Number of ports	8 LAN ports, Max. 64 WAN ports. Each WAN port has data rate n x 64K bps, 1 ≤ n ≤ 32 (≤ 8Mbps for total of all 64 WAN ports)
Physical Interface	10/100 BaseT x 8
Connector	RJ45
Routing protocol	RIP-I, RIP-II, OSPF, Static
Supporting Protocols	PPP (IPCP/BCP), MLPPP, HDLC, Frame Relay, and Cisco compatible HDLC, NAT/NAPT, DHCP
Diagnostic	Ping, Trace route
QoS	Rate limit

Terminal Server Interface

Connector	One DB-44 conversion cable to one DB-9 and two DB-25 connectors
Ports	One Async RS232 port, two Async/Sync RS232 ports. The two Async/Sync ports can be configured independently as Asynchronous or Synchronous.
Data Rate	Async: 1.2kbps, 2.4kbps, 4.8kbps, 9.6kbps, 19.2kbps, 38.4kbps Sync: 64 kbps
Layer 2 Protocol of RS232 Async	raw data
Layer 2 Protocol of RS232 Sync	PPP
Terminal Server Function	Supports Telnet
Router Function	RIP-I, RIP-II, Static Route

Optical Fiber Interface Characteristics

Optical Module	Fiber Direction	Wavelength (nm)	Connector	Distance (km)	Power (dB)
SAA	Dual uni-directional	1310	SC (Subscriber Connector)	30	19
SBB	Dual uni-directional	1310	SC (Subscriber Connector)	50	30
SCC	Dual uni-directional	1310	FC (Fiber Connector)	30	20
SDD	Dual uni-directional	1550	SC (Subscriber Connector)	20	12
SEE	Dual uni-directional	1550	SC (Subscriber Connector)	100	30
SSM	Single bi-directional (master)	1310/1550	SC (Subscriber Connector)	30	20
SSS	Single bi-directional (slave)	1550/1310	SC (Subscriber Connector)	30	20

NOTE: Other fiber optical options available on special order

G.SHDSL Line Interface

Number of ports	2 or 4
Line Rate for 4-channel G.shdsl	n x 64Kbps (n= 3 to 31)
Line Rate for 2-channel G.shdsl	n x 64Kbps (n= 3 to 15)
Line Code	16-TCPAM, full duplex with adaptive echo cancellation
Connector	RJ45
Electrical	Unconditioned 19-26 AWG twisted pair
Sealing current	Max. 20 MA source current
Clock Source	From System, Line
Diagnostic Test	G.SHDSL Loopback: To-LINE, To-bus BERT: QRSS

DTE Interface (X.21)

Data Port Up to six 6-port DTE X.21 card; 1-port DTE X.21 card
Data Rate 56 or 64 Kbps, n = 1 to 32
Connector DB15S

DTE Interface (V.35)

Data Port Up to six 6-port DTE V.35 card; ; 1-port V.35 card
Data Rate 56 or 64 Kbps, n = 1 to 32
Connector DB25S (optional conversion cable DB25S to M34 connector)

DTE Interface (V.36)

Data Port Up to six 6-port DTE V.36 card
Data Rate 56 or 64 Kbps, n = 1 to 32
Connector DB25S (optional conversion cable DB25S to DB37 connector)

DTE Interface (EIA530/RS449)

Data Port Up to six 6-port EIA530 DTE card; 1-port EIA530 card
Data Rate 56 or 64 Kbps, n = 1 to 32
Connector DB25S (optional conversion cable DB25S male to DB37 female connector for RS449)

DTE Interface (RS232)

Data Port 1-port RE232 card
Data Rate 56 or 64 Kbps *n, n=1 - 2
Mapping Any sequential time slots

DTE Interface (RS232-X.50 mux. 5-port)

Data Port Up to six 5-port RS232 cards with X.50 plug-in, subrate, with subrate mux
MUX (a) 5 independent RS232, or (b) 5 subrate RS232 (X.50) muxed to 64K
Data Rate Mode (a) 5 independent RS232 : 1.2K, 2.4K, 4.8K, 9.6K, 19.2K, 38.4K, 48K , 64K SYNC
1.2K, 2.4K, 4.8K, 9.6K, 19.2K ASYNC
Mode (b) 5 mux together : 1.2K, 2.4K, 4.8K, 9.6K SYNC
1.2K, 2.4K, 4.8K, 9.6K ASYNC

NOTE: Mode (a) and mode (b) cannot be mixed.

Connector DB25S

DTE Interface (RS232-X.50 mux. 8-port)

Data Port Up to twelve 8-port RS232 cards
MUX Maximum 5 subrate port per 64K bps
Data Rate Asynchronous Mux mode 0.6K, 1.2K, 2.4K, 4.8K, 9.6K
Independent mode 0.6K, 1.2K, 2.4K, 4.8K, 9.6K, 19.2K, 38.4K
Synchronous Mux mode 0.6K, 1.2K, 2.4K, 4.8K, 9.6K
Independent mode 0.6K, 1.2K, 2.4K, 4.8K, 9.6K, 19.2K, 38.4K, 48K, 64K

Port Number

Card Type	1	2	3	4	5	6	7	8
Eight RJ48	Async	Async	Async	Async	Async	Async	Async	Async

Two DB44 + Two RJ48	Async/Sync	Async/Sync	Async	Async/Sync	Async/Sync	Async	Async	Async
---------------------	------------	------------	-------	------------	------------	-------	-------	-------

Connector Eight RJ48 (port 1 to port 8)
DB44 (port1,port2,port3), DB44 (port4,port5,port6), RJ48 (port7) and RJ48(port8)

Conversion Cable A three-into-one conversion cable adapts the DB44 connector to 3 connectors (one DB9S and two DB25S)

Electrical RS232 Interface, DCE

DTE Interface (Data Bridge Card)*

Data Port Up to twelve 8-port data bridge card (each card supports up to 120 DS0 for data bridge)
Feature 20 end points per multi-drop circuit to into a logical ended 56K channel
Per port supports bridge function to N remote Trib. Site (N=1~20)
Data Rate Asynchronous Support to receive 1200 to 19200 bps asynchronous data via oversampling channel
Bridge function one port with one DS-0 to many (Maximum is 20 for remote Tributary data box)
20 drops for each DS0 to remote Tributary data box and 8 ports RS232 shared the 128 channels.

Co-directional Interface

Interface	ITU G.703 64 Kbps co-directional interface
Connector	120ohm, RJ48
Line Distance	Up to 500 meters
Loopack	DTE Payload Loopback, Local Loopback

C37.94 Interface

Source	LED
Wavelength	820nm 2Km reach
Connector	ST
Optical Budget	50 Mircon core/9.6 db 62.5 Mircon core/ 15db

Dry Contact Interface

Inputs -		Outputs -	
8-channel	2-port per card, 4-pair per port	8-channel	8-pair per card
Connector	RJ45	Connector	Screw type
Internal Resistance	1 K	Initial Insulation Resistance	Min. 100M ohm (at 500 Vdc)
Activation Current	3 ma	Max. Current	5A
Deactivation Current	1.5 ma	Max. Voltage	100 Vdc, 250 Vac
Allowable Current	4 ma		

Dry Contact Type B Interface

Inputs -		Outputs -	
8-channel	2-port per card, 4-pair per port	8-channel	8-pair per card
Connector	RJ45	Connector	Screw type
Internal Resistance	100 K	Initial Insulation Resistance	Min. 100M ohm (at 500 Vdc)
Activation Current	3 ma	Max. Current	2A
Deactivation Current	1.5 ma	Max. Voltage	220 Vdc, 250 Vac
Allowable Current	4 ma		

Voice Card (Q2EM, Q4EM)

Connector	One 44-pin connector, adapter cable included for 4 RJ45 connectors.
Power	110-220Vac, -24Vdc, -48Vdc
Alarm Conditioning	CGA busy after 2.5 seconds of LOS, LOF
Encoding	A-law or μ -law, user selectable as a group
Impedance	Balanced 600 Ω or 900 Ω
Longitudinal Rejection	55 dB
Longitudinal Max	2.5 volts peak AC
Longitudinal Balance	> 63dB
Gain Adjustment	0, -3, -6 or +7 dB for transmit (D/A) gain
(all port settings)	0, -3, -6 or +10 dB for receive (A/D) gain

Signal/Distortion	> 46dB with 1004 Hz, 0dBm input
Frequency Response	- 0.25 to -1 dB from 300 to 3400 Hz
Idle Channel Noise	< 20 dBmC0
Signaling	Type 1, Type 2, Type 3, Type 4, Type 5, and also TO (Transmit Only)
Modems	Full compatibility with V.90 modems
E Lead Sensor Current	0.25 mA (minimum)
Signaling Bit Setting	Jump Selectable
Operational Temp.	0°C to +50°C
Relative Humidity	0% to 95%

- All in-band signaling tones are carried transparently by the digitizing process.
- Customer is responsible for in-band signaling compatibility between a telephone and a switch, or between a PBX and a switch.

Voice Card (8EM)

Connector	Eight RJ45
Alarm Conditioning	CGA busy after 2.5 seconds of LOS, LOF
Encoding	A-law or μ -law, user selectable together for all
Impedance	Balanced 600 or 900 ohms
Longitudinal Conversion Loss	> 46dB
Longitudinal Balance	> 63dB
Gain Adjustment (Per-port setting)	-10 to +7 dB / 0.1dB step for transmit (D/A) gain -10 to +14 dB / 0.1dB step for receive (A/D) gain
I/O voice power range	A/D digital input level: -66 dBm (0.00039 Vrms) ~ + 3 dBm (1.09 Vrms) D/A analog output level: -66 dBm (0.00039 Vrms) ~ + 7 dBm (1.74 Vrms)
Signal/Distortion	> 25dB with 1004 Hz, 0dBm input
Frequency Response	- 0.25 to -1 dB from 300 to 3400 Hz
Carrier connection	Side A (exchange side) and Side B (carrier side) setup by side switch
Idle Channel Noise	Max. -65 dBm0p
wire mode	2 wire and 4 wire (programmable)
Signaling	Type 1, Type 2, Type 3, Type 4, and Type 5, Transmit only (programmable)
Modems	Full compatibility with V.90 modems
	<ul style="list-style-type: none">• All in-band signaling tones are carried transparently by the digitizing process.• Customer is responsible for in-band signaling compatibility between a telephone and a switch, or between a PBX and a switch.

Voice Card 12 MAG (Magneto)

Connector	Twelve RJ11
Alarm Conditioning	CGA busy after 2.5 seconds of LOS, LOF
Encoding	A-law or μ -law, user selectable together for all
Impedance	Balanced 600 or magneto telephone impedance match
Longitudinal Conversion Loss	> 46dB
Gain Adjustment	-21 to +10 dB / 0.1dB step transmit & receive
Signal/ Distortion	> 25dB with 1004 Hz, 0dBm input
Frequency Response	- 0.25 to -1 dB from 300 to 3400 Hz, coincide with ITU-T G.712
Idle Channel Noise	Max. -65 dBm0p
Min Detectable Ringing Voltage	16 Vrms
Ringing Detectable Across	L1 and L2 (Tip and Ring), L1 and GND (Tip and GND)
Ringing Generation	Voltage: 76 Vrms (sine wave) Frequency: 20Hz (with optional choices of 16, 25, 50 Hz) Cadence: 1. Normal: Ring after crank 2. PLAR ON: -Single Ring Type: ring for 2 sec. and stop, or ring for 4 sec. and stop -Continuous Ring Type: 1 sec on 2 sec off, or 2 sec on 4 sec off
Ringing Send Across	L1 and L2 (Tip and Ring), L1 and GND (Tip and GND)
Signaling	Magneto MRD(Ringing across Tip and Ring or Tip and Ground)
Signaling Bit A,B,C,D	Programmable
	Signaling is carried transparently by the digitizing process.
	<ul style="list-style-type: none">• Use Magneto card default setting for communications between magneto telephones• Use Magneto card PLAR mode setting for communications between a magneto telephone and a regular telephone

Conference Card

RS232 Interface

Data Port	2-ports per card
ASYNC Data Rate	300, 600, 1.2K, 2.4K, 4.8K, 9.6K, 19.2K
SYNC	not supported
Connector	Two DB9, DCE, female

FXS Voice Interface

Connector	Two RJ11
Encoding	G.723
Longitudinal Conversion Loss	> 46dB
Cross Talk Measure	Max -70dBm0
Gain Adjustment	transmit (D/A) gain 0, +6dB receive (A/D) gain +6, 0, -6dB
Signal/ Distortion	> 25dB with 1004 Hz, 0dBm input
Idle Channel Noise	Max. -65 dBm0p
Loop Resistance	Max 1800 ohm
FXS Loop Feed	-48 Vdc with 25mA current limit per port
FXS Ringing	2 REN 20Hz 76 Vrms 2 sec on / 4 sec off for 1 min, or 1 sec on / 2 sec off for 30 sec (programmable)
Signaling	Loop Start, DTMF

E&M Voice Interface

Connector	Two RJ45
Encoding	G.723
Impedance	Balanced 600 ohms
Longitudinal Conversion Loss	> 46dB
Gain Adjustment	transmit (D/A) gain 0, +6dB receive (A/D) gain +6, 0, -6dB
Signal/Distortion	> 25dB with 1004 Hz, 0dBm input
Idle Channel Noise	Max. -65 dBm0p
Carrier Connection	Side A = exchange side, Side B = carrier side (Jumper selectable)
Phone line power+12V	Type P (Jumper enable)
Operation mode	Master, standard (Jumper selectable)
Wire Mode	4 wire
Signaling Type	Type 1, Type 4, and Type 5 (Jumper selectable)
EM Ringing	Single rainging for 5 sec only 2 sec on / 4 sec off for 1 min, or 1 sec on / 2 sec off for 30 sec (programmable)

Voice Card (QFXS, QFXO)

Quad FXS voice card (4 FXS per plug-in)	
Quad FXO voice card (4 FXO per plug-in)	
Connector	QFXS: 1, 2, 3, or 4 FXS per RJ11 connector, QFXO: 1, 2, 3, or 4 FXO per RJ11 connector
Power for QFXS	110-220Vac, -24Vdc or -48Vdc
Power for QFXO	110-220Vac, -24Vdc, and -48Vdc
Alarm Conditioning	CGA busy after 2.5 seconds of LOS, LOF
Encoding	A-law or μ -law, user selectable together for all
AC impedance	Balanced 600 or 900 ohms (selectable together for all)
Longitudinal Rejection	55 dB
Loss Adjustment	0, 3, 6, or 9 dB transmit & receive
Signal/ Distortion	> 46dB with 1004 Hz, 0dBm input
Frequency Response	- 0.25 to -1 dB from 300 to 3400 Hz
FXS Loop Feed	-48Vdc or -24Vdc with 25mA current limit per port Jumper Selectable: 25mA, 30mA, 35mA
FXO	Ringling REN 0.5B (AC) Detectable Ringing 25 Vrms Loop Resistance $\leq 1800 \Omega$ DC impedance (ON-HOOK) > 1M Ω DC impedance(OFF-HOOK) 235 Ω @ 25mA feed 90 Ω @ 100mA feed
FXS Ringing	Support 2 REN per port (1 REN = 6930 Ω + 8 μ F) 20 Hz, other frequencies: 16.7Hz, 25 Hz, 50Hz (Jump selectable) 78 Vrms (sine wave) (45 Vrms to 86 Vrms wide range by Resistor selectable) 2 sec on 4 sec off, or 1 sec on 2 sec off optional for PLAR
Metering Pulse	12KHz/ 16KHz <ul style="list-style-type: none">• Power: 10dBm• Sensitivity: -27dBm (-21dBm to -45dBm by Resistor selectable)
Signaling	Loop Start, GND-Start, Metering Pulse (12KHz, 16KHz), DTMF, Dialing Pulse, PLAR, Battery Reverse (supports Line Reverse Signaling for Billing)
	<ul style="list-style-type: none">• All in-band signaling tones are carried transparently by the digitizing process.• Customer is responsible for in-band signaling compatibility between a telephone and a switch, or between a PBX and a switch.• -24Vdc power is for FXS PCB version C and up

Voice Card (12FXS, 12FXO, 24FXS, 24FXO)

12 FXS/FXO Connector	Twelve RJ11
24 FXS/FXO Connector	One RJ21X
Alarm Conditioning	CGA busy after 2.5 seconds of LOS, LOF
Encoding	A-law or μ -law, user selectable together for all
AC Impedance	Balanced 600 or 900 ohms (selectable together for all)
Longitudinal Conversion Loss	> 46dB
Cross talk measure	Max -70dBm0
Gain Adjustment	-21 to +10 dB / 0.1dB step transmit & receive
Signal/ Distortion	> 25dB with 1004 Hz, 0dBm input
Frequency Response	- 0.25 to -1 dB from 300 to 3400 Hz, coincide with ITU-T G.712
Idle Channel Noise	Max. -65 dBm0p
Variation of Gain	± 0.5 dB
FXO	Ringling REN 0.5B (AC) Detectable Ringing 25 Vrms Loop Resistance $\leq 1800 \Omega$ DC Impedance (ON-HOOK) > 1M Ω DC Impedance (OFF-HOOK) 235 Ω @ 25mA feed 90 Ω @ 100mA feed
FXS Loop Feed	-48Vdc or -24Vdc with 25mA current limit per port Jumper Selectable: 25mA, 30mA, 35mA
FXS signalling	Normal / Automatic Ring down
FXS Ringing	1 REN at 5K meters per port 16.7Hz, 20Hz, 25Hz, 50Hz, user selectable for all ports 38 to 85 Vrms (sine wave), 76 Vrms for default Ring Voltage 2 sec on 4 sec off, or 1 sec on 2 sec off optional for PLAR
Signaling	Loop Start, DTMF, pulse, PLAR, Battery Reverse
Optional Signaling (for special order)	Ground Start, Metering pulse (12 KHz, 16 KHz), and P(in PLAR mode, PLAR signalling bits are programmable.
Signaling Bit A,B,C,D	Programable bit
	<ul style="list-style-type: none">• All in-band signaling tones are carried transparently by the digitizing process.• Customer is responsible for in-band signaling compatibility between a telephone and a switch, or between a PBX and a switch.• -24Vdc power is for FXS PCB version L and up

TDMoE

Combo Gigabit Ethernet(GbE) Interface

Number of Ports	2
Speed	10/100/1000M bps
Connector	RJ45 for twisted pair GbE, LC for optical GbE, auto detection

Gigabit Ethernet(GbE) Interface

Number of Port	2
Speed	10/100/1000 BaseT
Connector	RJ45

Ethernet Function

Basic Features	MDI/MDIX for 10/100/1000M BaseT auto-sensing Ping function contained ARP Per port, programmable MAC hardware address learn limiting (max. MAC table 8192 (8k) entry) Packet Delay Variation: <ul style="list-style-type: none">- Unframed T1: Up to 340 ms- Framed T1: Up to 256 ms- E1: up to 256 ms- Framed T1 with CAS: Up to 192 ms
Packet Transparency	Packet transparency support for all types of packet types including IEEE 802.1q VLAN and 802.1ad (Q-in-Q)
QoS	User configurable 802.1p CoS, ToS in out going IP frame
Traffic Control	Ingress packet Rate limiting buckets per port for ethernet port Supporting Rate-based and Priority-based rate limiting for LAN port Granularity: <ul style="list-style-type: none">a. From 64 Kbps to 1 Mbps in increments of 64 Kbpsb. From 1 Mbps to 100 Mbps in increments of 1 Mbpsc. From 100 Mbps to 1000 Mbps in increments of 10Mbps Pause frame issued when the traffic exceeding the limited rate before packet dropped following IEEE802.3X
Link Aggregation	WAN support link aggregation

Jitter & Wander

PPM: per G.823 Traffic
PPB: per G.823 Synchronous*

Standard Compliance

IETF	TDMoIP (RFC5087), SAToP (RFC4553), CESoPSN (RFC5086)
IEEE	802.1q, 802.1p, 802.1d, 802.3, 802.3u, 802.3x, 802.3z, 802.1s, 802.1w, 802.1AX

SFP Modules for TDMoE:

1.25G (mini GBIC) Dual Fiber Commercial (0 to 70°C)	MTAFW	Multi-mode optical module with dual uni-directional fiber, 1.25G, 850nm, 550m, LC connector w/o DDM, 1000Base-SX	<ul style="list-style-type: none"> ▪ Use 2 fibers for all SFP optical modules ▪ All 1.25G optical module downgrading to 622Mbps data rate will be workable
	MTAFD	Single-mode optical module with dual uni-directional fiber, 1.25G, 850nm, 550m, LC connector with DDM, 1000Base-SX	
	MTBTD	Single-mode optical module with dual uni-directional fiber, 1.25G, 1310nm, 2Km, LC connector with DDM, 1000Base-SX+	
	MTBTW	Multi-mode optical module with dual uni-directional fiber, 1.25G, 1310nm, 2Km, LC connector w/o DDM, 1000Base-SX+	
	PTB2W	Single-mode optical module with dual uni-directional fiber, 1.25G, 1310nm, 20Km, LC connector w/o DDM, 1000Base-LX	
	PTB4W	Single-mode optical module with dual uni-directional fiber, 1.25G, 1310nm, 40Km, LC connector w/o DDM, 1000Base-LHX	
	PTC5W	Single-mode optical module with dual uni-directional fiber, 1.25G, 1550nm, 50Km, LC connector w/o DDM, 1000Base-XD	
	PTC6W	Single-mode optical module with dual uni-directional fiber, 1.25G, 1550nm, 60Km, LC connector w/o DDM, 1000Base-XD	
	PTC8W	Single-mode optical module with dual uni-directional fiber, 1.25G, 1550nm, 80Km, LC connector w/o DDM, 1000-Base-ZX	
	PTC9W	Single-mode optical module with dual uni-directional fiber, 1.25G, 1550nm, 90Km, LC connector w/o DDM, 1000Base-ZY	
	PTCVW	Single-mode optical module with dual uni-directional fiber, 1.25G, 1550nm, 110Km, LC connector w/o DDM, , 1000Base-APD	
	PTCXW	Single-mode optical module with dual uni-directional fiber, 1.25G, 1550nm, 120Km, LC connector w/o DDM1000Base-APD	
	PTB1D	Single-mode optical module with dual uni-directional fiber, 1.25G, 1310nm, 10Km, LC connector with DDM, 1000Base-LX	
	PTB3D	Single-mode optical module with dual uni-directional fiber, 1.25G, 1310nm, 30Km, LC connector with DDM, 1000Base-LHX	
	PTB4D	Single-mode optical module with dual uni-directional fiber, 1.25G, 1310nm, 40Km, LC connector with DDM, 1000Base-LHX	
	PTC5D	Single-mode optical module with dual uni-directional fiber, 1.25G, 1550nm, 50Km, LC connector with DDM, 1000Base-XD	
	PTC6D	Single-mode optical module with dual uni-directional fiber, 1.25G, 1550nm, 60Km, LC connector with DDM, 1000Base-XD	
	PTC8D	Single-mode optical module with dual uni-directional fiber, 1.25G, 1550nm, 80Km, LC connector with DDM, 1000Base-ZX	
	PTC9D	Single-mode optical module, with dual unidirectional fiber, 1.25G, 1550nm, 90Km, LC connector with DDM	
	PTCVD	Single-mode optical module with dual uni-directional fiber, 1.25G, 1550nm, 110Km, LC connector with DDM, 1000Base-APD	
PTCXD	Single-mode optical module with dual uni-directional fiber, 1.25G, 1550nm, 120Km, LC connector with DDM, DDM1000Base-APD		

622M-1.25G (mini GBIC) Dual Fiber Commercial (0 to 70°C)	PKB1W	Single-mode optical module with dual uni-directional fiber, 622Mbps~1.25G, 1310nm, 10Km, LC connector w/o DDM, 1000Base-LX	
---	--------------	--	--

1.25G (mini GBIC) Bi-directional Single Fiber Commercial (0 to 70°C)	PTD1W	Single mode optical module with single bi-directional fiber, 1.25G, Tx 1310 nm / Rx 1550 nm, 10Km, LC connector w/o DDM, GbE/1X fiber channel	<ul style="list-style-type: none"> ▪ 1310 nm from master to slave ▪ Order PTD1W to use with PTE1W ▪ Use 1 fiber
	PTE1W	Single mode optical module with single bi-directional fiber, 1.25G, Tx 1550 nm / Rx 1310 nm, 10Km, LC connector w/o DDM, GbE/1X fiber channel	<ul style="list-style-type: none"> ▪ 1550 nm from slave to master ▪ Order PTE1W to use with PTD1W ▪ Use 1 fiber
	PTD2W	Single mode optical module with single bi-directional fiber, 1.25G, Tx 1310 nm / Rx 1550 nm, 20Km, LC connector w/o DDM, GbE/1X fiber channel	<ul style="list-style-type: none"> ▪ 1310 nm from master to slave ▪ Order PTD2W to use with PTE2W ▪ Use 1 fiber
	PTE2W	Single mode optical module with single bi-directional fiber, 1.25G, Tx 1550 nm / Rx 1310 nm, 20Km, LC connector w/o DDM, GbE/1X fiber channel	<ul style="list-style-type: none"> ▪ 1550 nm from slave to master ▪ Order PTE2W to use with PTD2W ▪ Use 1 fiber
	PTD4W	Single mode optical module with single bi-directional fiber, 1.25G, Tx 1310 nm / Rx 1550 nm, 40Km, LC connector w/o DDM, GbE/1X fiber channel	<ul style="list-style-type: none"> ▪ 1310 nm from master to slave ▪ Order PTD4W to use with PTE4W ▪ Use 1 fiber
	PTE4W	Single mode optical module with single bi-directional fiber, 1.25G, Tx 1550 nm / Rx 1310 nm, 40Km, LC connector w/o DDM, GbE/1X fiber channel	<ul style="list-style-type: none"> ▪ 1550 nm from slave to master ▪ Order PTE4W to use with PTD4W ▪ Use 1 fiber
	PTD6W	Single mode optical module with single bi-directional fiber, 1.25G, Tx 1310 nm / Rx 1550 nm, 60Km, LC connector w/o DDM, GbE/1X fiber channel	<ul style="list-style-type: none"> ▪ 1310 nm from master to slave ▪ Order PTD6W to use with PTE6W ▪ Use 1 fiber
	PTE6W	Single mode optical module with single bi-directional fiber, 1.25G, Tx 1550 nm / Rx 1310 nm, 60Km, LC connector w/o DDM, GbE/1X fiber channel	<ul style="list-style-type: none"> ▪ 1550 nm from slave to master ▪ Order PTE6W to use with PTD6W ▪ Use 1 fiber
	PTD1D	Single mode optical module with single bi-directional fiber, 1.25G, Tx 1310 nm / Rx 1550 nm, 10Km, LC connector with DDM, GbE/1X fiber channel	<ul style="list-style-type: none"> ▪ 1310 nm from master to slave ▪ Order PTD1D to use with PTE1D ▪ Use 1 fiber
	PTE1D	Single mode optical module with single bi-directional fiber, 1.25G, Tx 1550 nm / Rx 1310 nm, 10Km, LC connector with DDM, GbE/1X fiber channel	<ul style="list-style-type: none"> ▪ 1550 nm from slave to master ▪ Order PTE1D to use with PTD1D ▪ Use 1 fiber
	PTD2D	Single mode optical module with single bi-directional fiber, 1.25G, Tx 1310 nm / Rx 1550 nm, 20Km, LC connector with DDM, GbE/1X fiber channel	<ul style="list-style-type: none"> ▪ 1310 nm from master to slave ▪ Order PTD2D to use with PTE2D ▪ Use 1 fiber
	PTE2D	Single mode optical module with single bi-directional fiber, 1.25G, Tx 1550 nm / Rx 1310 nm, 20Km, LC connector with DDM, GbE/1X fiber channel	<ul style="list-style-type: none"> ▪ 1550 nm from slave to master ▪ Order PTE2D to use with PTD2D ▪ Use 1 fiber
	PTD4D	Single mode optical module with single bi-directional fiber, 1.25G, Tx 1310 nm / Rx 1550 nm, 40Km, LC connector with DDM, GbE/1X fiber channel	<ul style="list-style-type: none"> ▪ 1310 nm from master to slave ▪ Order PTD4D to use with PTE4D ▪ Use 1 fiber
	PTE4D	Single mode optical module with single bi-directional fiber, 1.25G, Tx 1550 nm / Rx 1310 nm, 40Km, LC connector with DDM, GbE/1X fiber channel	<ul style="list-style-type: none"> ▪ 1550 nm from slave to master ▪ Order PTE4D to use with PTD4D ▪ Use 1 fiber
	PTD6D	Single mode optical module with single bi-directional fiber, 1.25G, Tx 1310 nm / Rx 1550 nm, 60Km, LC connector with DDM, GbE/1X fiber channel	<ul style="list-style-type: none"> ▪ 1310 nm from master to slave ▪ Order PTD6D to use with PTE6D ▪ Use 1 fiber
	PTE6D	Single mode optical module with single bi-directional fiber, 1.25G, Tx 1550 nm / Rx 1310 nm, 60Km, LC connector with DDM, GbE/1X fiber channel	<ul style="list-style-type: none"> ▪ 1550 nm from slave to master ▪ Order PTE6D to use with PTD6D ▪ Use 1 fiber
PTD8D	Single mode optical module with single bi-directional fiber, 1.25G, Tx 1310 nm / Rx 1550 nm, 80Km, LC connector with DDM, GbE/1X fiber channel	<ul style="list-style-type: none"> ▪ 1310 nm from master to slave ▪ Order PTD8D to use with PTE8D ▪ Use 1 fiber 	

	PTE8D	Single mode optical module with single bi-directional fiber, 1.25G, Tx 1550 nm / Rx 1310 nm, 80Km, LC connector with DDM, GbE/1X fiber channel	<ul style="list-style-type: none"> ▪ 1550 nm from slave to master ▪ Order PTE8D to use with PTD8D ▪ Use 1 fiber
--	--------------	--	--

NOTE: For other special optical modules, please contact your nearest Loop sales representative.

Clock Source

Internal, E1/T1 Line, External

Alarm Relay

Alarm Relay: max. voltage 3Vdc/ max. current: 1A
Fuse alarm, and performance alarm

System Configuration Parameters

Active Configuration, Stored Configuration, and Default Configuration (Stored in Non-volatile Memory)

Supervisor

RS232 Console Port (VT100) 10 Base-T, Ethernet, SNMP
In-band 64 Kbps
supports HDLC/PPP, SSH

Performance Monitor

Performance Registers Last 24 hours performance in 15 minute intervals and last 7 days in 24 hour summaries
Separate Registers Network, user, and remote site
Performance Reports Reports include E1 Bursty Errored Second, Severe Errored Second, Degraded Minutes. Also available in Statistics (%)
Alarm Queue To record the latest alarm type, location, and date & time
Threshold Bursty Seconds, Severely Errored Second, Degraded Minutes

Diagnostics

Loopback E1/T1 interface (Line Loopback, Payload Loopback, Local Loopback), DTE Loopback (DTE-to-DTE, DTE to Line)
Test Pattern For Controller: 2²¹-1, 2¹⁵-1, 2¹¹-1, 2⁹-1, and 4-byte user define pattern

Front Panel

LED 1 per V.35-interface, ACO, Power, SYNC/TEST, LOF, BPV, RAI/AIS

Physical /Electrical

	AM3440-A	AM3440-B	AM3440-C
Dimensions	432.4 x 220 x 223.5 mm (W×H×D)	438 x 110 x 224 mm (W×H×D)	438 x 132 x 224 mm (W×H×D)
Power	Single/ Dual -48 Vdc: -36 to -75 Vdc, 100 Watts max. Single/ Dual -48 Vdc: -36 to -75 Vdc, 150 Watts max. Single/ Dual -24 Vdc: -18 to -36 Vdc, 150 Watts max Single/ Dual -125 Vdc: -40 to -150 Vdc, 100 Watts max	Single/ Dual -48 Vdc: -36 to -75 Vdc, 100 Watts max. Single AC: 100 to 240 Vac, 50/60 Hz Single/ Dual -24 Vdc: -36 to -75 Vdc, 150 Watts max	Single/ Dual -48 Vdc: -36 to -75 Vdc, 100 Watts max. Single AC: 100 to 240 Vac, 50/60 Hz Single/ Dual -24 Vdc: -36 to -75 Vdc, 150 Watts max
Temperature	0-55°C	0-55°C	0-55°C
Humidity	0-95%RH (non-condensing)	0-95%RH (non-condensing)	0-95%RH (non-condensing)
Mounting	Desk-top stackable, 19" /23" rack mountable	Desk-top stackable, 19" /23" rack mountable	Desk-top stackable, 19" /23" rack mountable
Line Power Supply	Available only with DC power for G.SHDSL card only	N/A	N/A
Power Consumption	Max 110 Watts	Max 45 Watts	Max 57 Watts

Certification

AM3440-A	AM3440-B	AM3440-C
EN55022 Class A, EN50024, FCC Part 15 Class A, FCC Part 68, CS-03, IEC60950, UL60950, IEC 61850-3, IEEE 1613	EN55022 Class A, EN50024, EN300 386, FCC Part 15 Class A, FCC Part 68, CS-03, IEC60950-1, EN60950-1	EN55022 Class A, EN50024, EN300 386, FCC Part 15 Class A, IEC60950-1, EN60950-1

Note for IEC 61850-3 and IEEE1613:

- (1) The certification only applies to AM3440-A, -48Vdc(150W) power module
- (2) The magneto card does not support IEC 61850-3 and IEEE 1613
- (3) Use shielding cable with the following modules:

- Console port of CCA
- Single EIA530
- Router-A
- Input Port of Dry Contact
- V.36/RS449/EIA530
- SNMP of CCA
- Single V.35
- ATM/FR E1/T1
- Input Port of Dry Contact B
- X.21
- Single RS232
- Terminal Server
- RS232-X.50
- RS232 X.50-8
- Single X.21
- Router
- DTE of Conference
- V.35

Compliance

ITU G.703, G.704, G.706, G.732, G.736, G.823, G.826, G.711, G.712, G.775, O.151, V.11, V.28, V.54

Specifications for Loop-VV Y-BOX**LINE**

Connector	BNC or RJ48C
Port Number	For Y-BOX with BNC connectors: 4 line ports For Y-BOX with RJ48C connectors: 16 line ports
Protection	For Y-BOX with BNC connectors: support 2 Quad E1 plug-in card, 4 active E1, 4 standby E1 For Y-BOX with RJ48C connectors: support 8 Quad E1 plug-in cards, 16 active E1, 16 standby E1 For Y-BOX with RJ48C connectors: support 8 Quad T1 plug-in cards, 16 active T1, 16 standby T1

Mechanical

Height	44.5 mm/ 1.75 in
Width	432 mm/ 17 in
Depth	100 mm/ 3.9 in

* Future Option

Application Illustration:

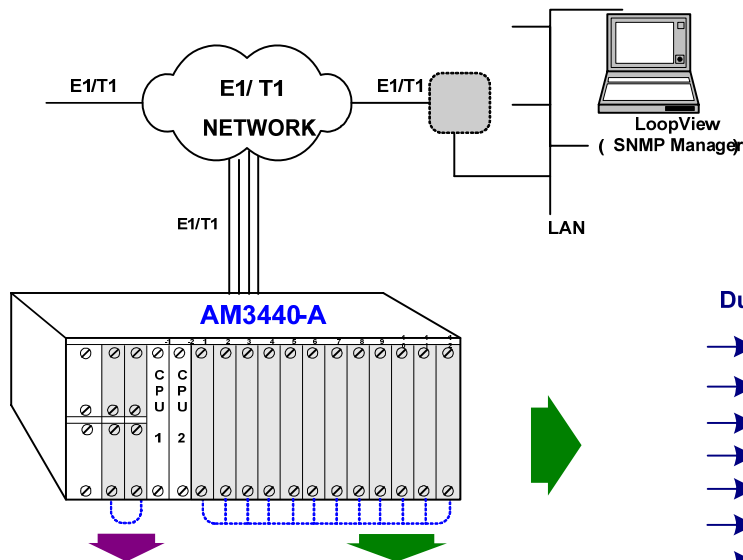

Mini-Slot plug-in Cards

- ➔ 1 - channel E1
- ➔ 1 - channel T1
- ➔ Mini Quad E1
- ➔ 1 - channel E1 ATM Frame Relay
- ➔ 1 - channel T1 ATM Frame Relay
- ➔ 32 WAN port Router
- ➔ 64 WAN port Router
- ➔ Fiber Optical Interface
- ➔ 3 - channel Terminal Server
- ➔ 1 - channel DTE (1X.21, 1V.35, 1RS232, or 1EIA530)

Single-Slot plug-in Cards

- ➔ 3 - channel E1(future option)
- ➔ 4 - channel E1
- ➔ 4 - channel T1
- ➔ 8 - channel OCU-DP
- ➔ 2 - channel G.SHDSL w/o line power
- ➔ 4 - channel G SHDSL w/o line power
- ➔ 8 - channel G.703 64 Kbps
- ➔ 8 - channel Dry Contact I/O
- ➔ 8 - channel Dry Contact I/O type B
- ➔ 8 - channel 2 W/4 W E&M
- ➔ 12- channel FXS
- ➔ 12- channel FXO
- ➔ 12- channel Magneto
- ➔ 1 - channel C37.94
- ➔ 4 - channel C37.94
- ➔ 8 - channel RS232 with X.50 subrate
- ➔ 8 - LAN-port /64-WAN-port Router -B
- ➔ Conference card
- ➔ TDMoE
- ➔ 8- Data Bridge (future option)

Dual-slot plug-in cards:

- ➔ 6 - channel X.21/V.11
- ➔ 6 - channel V.35
- ➔ 6 - channel V.36
- ➔ 6 - channel EIA530/RS449
- ➔ 5 - channel RS232 with X.50 subrate
- ➔ 24- channel FXS
- ➔ 24- channel FXO
- ➔ 2 - channel G.SHDSL w/line power
- ➔ 4 - channel G.SHDSL w/line power

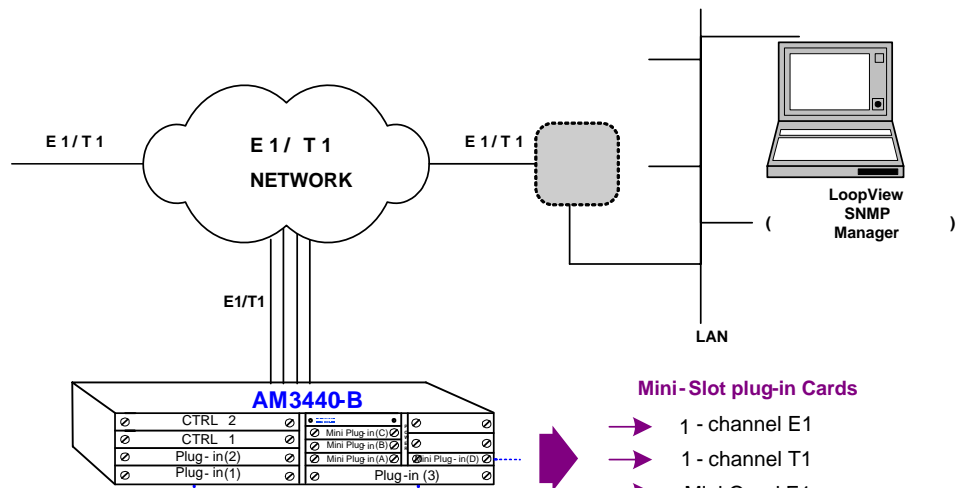

Mini-Slot plug-in Cards

- 1 - channel E1
- 1 - channel T1
- Mini Quad E1
- 1 - channel E1 ATM Frame Relay
- 1 - channel T1 ATM Frame Relay
- 32 WAN port Router
- 64 WAN port Router
- Fiber Optical Interface
- 3 - channel Terminal Server
- Quad 2 W/4 W E&M
- QFXS/QFXO
- 1 - channel DTE (1X.21, 1V.35, 1RS232, or 1EIA530)

Dual-slot plug-in cards:

- 6 - channel X.21/V.11
- 6 - channel V.35
- 6 - channel V.36
- 6 - channel EIA530/RS449
- 5 - channel RS232 with X.50 substrate
- 24 - channel FXS
- 24 - channel FXO

Single-Slot plug-in Cards:

- 3 - channel E1 (future option)
- 4 - channel E1
- 4 - channel T1
- 8 - channel OCU - DP
- 2 - channel G.SHDSL w/o line power
- 4 - channel G.SHDSL w/o line power
- 8 - channel G.703 64 Kbps
- 8 - channel Dry Contact I/O
- 8 - channel Dry Contact I/O Type B
- 8 - channel 2W/4W E&M
- 12 - channel FXS
- 12 - channel FXO
- 12 - channel Magneto
- 1 - channel C37.94
- 4 - channel C37.94
- 8 - channel RS232 with X.50 substrate
- 8 - LAN-port / 64 - WAN - port Router -B
- Conference card
- TDMoE
- 8 - Data Bridge (future option)

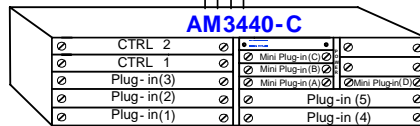
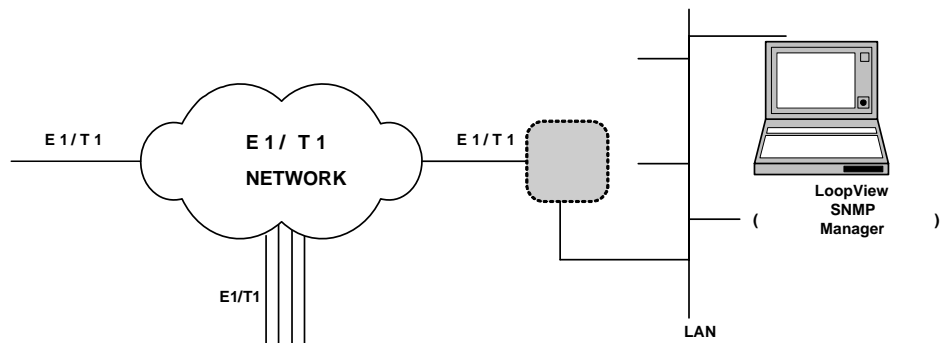

Mini-Slot plug-in Cards

- ➔ 1 - channel E1
- ➔ 1 - channel T1
- ➔ Mini Quad E1
- ➔ 1 - channel E1 ATM Frame Relay
- ➔ 1 - channel T1 ATM Frame Relay
- ➔ 32 WAN port Router
- ➔ 64 WAN port Router
- ➔ Fiber Optical Interface
- ➔ 3 - channel Terminal Server
- ➔ Quad 2 W/4W E&M
- ➔ QFXS / QFXO
- ➔ 1 - channel DTE (1X.21, 1V.35, 1RS232, or 1EIA530)

Dual-slot plug-in cards:

- ➔ 6 - channel X.21/V.11
- ➔ 6 - channel V.35
- ➔ 6 - channel V.36
- ➔ 6 - channel EIA530/RS449
- ➔ 5 - channel RS232 with X.50 substrate
- ➔ 24 - channel FXS
- ➔ 24 - channel FXO

Single-Slot plug-in Cards:

- ➔ 3 - channel E1 (future option)
- ➔ 4 - channel E1
- ➔ 4 - channel T1
- ➔ 8 - channel OCU - DP
- ➔ 2 - channel G.SHDSL w/o line power
- ➔ 4 - channel G.SHDSL w/o line power
- ➔ 8 - channel G.703 64 Kbps
- ➔ 8 - channel Dry Contact I/O
- ➔ 8 - channel Dry Contact I/O type B
- ➔ 8 - channel 2W/4W E&M
- ➔ 12 - channel FXS
- ➔ 12 - channel FXO
- ➔ 12 - channel Magneto
- ➔ 1 - channel C37.94
- ➔ 4 - channel C37.94
- ➔ 8 - channel RS232 with X.50 substrate
- ➔ 8 - LAN-port / 64 - WAN - port Router -B
- ➔ Conference card
- ➔ TDMoE
- ➔ 8 - Data Bridge (future option)

ULSR Ring Application

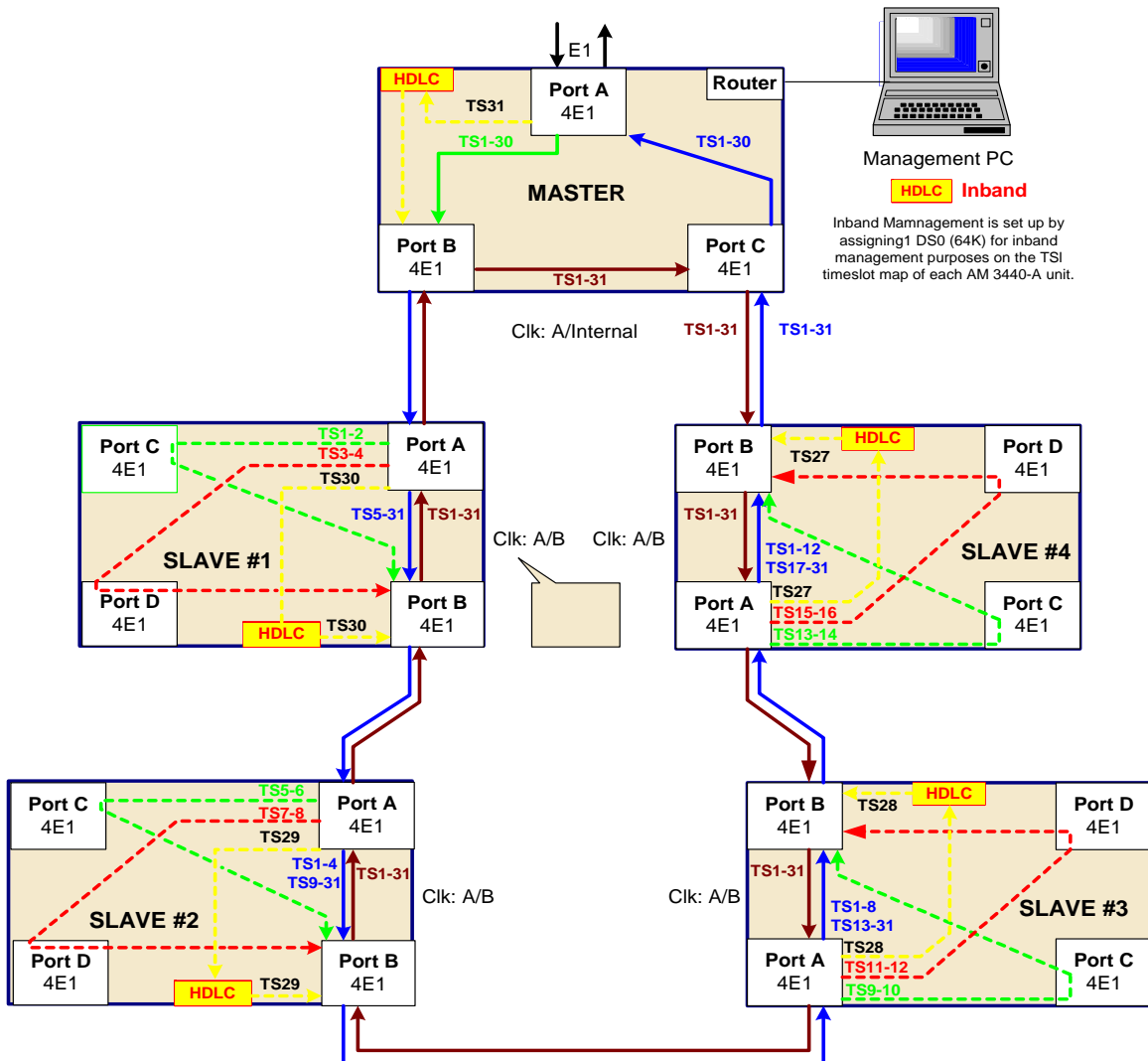

Note: ULSR ring does not support E1 unframe mode. Users must use E1 frame mode to set up a ULSR ring.

 <p>Loop Telecom LoopTelecom.com</p>	<h2>LOOP TELECOMMUNICATION INTERNATIONAL, INC.</h2> <h3>ISO 9001/ISO 14001</h3>		
<p>Worldwide 8F, No. 8, Hsin Ann Road, Science-Based Industrial Park Hsinchu, Taiwan 30078 Tel:+886-3-578-7696 Fax:+886-3-564-6272 www.LoopTelecom.com sales@loop.com.tw</p>	<p>Taipei, Taiwan 6F, No. 36, Alley 38, Lane 358, Rueiguang Road, Neihu, Taiwan 11492 Tel:+886-2-2659-0399 Fax:+886-2-2659-2325 michael_tzeng@loop.com.tw</p>	<p>North America 8 Carrick Road Palm Beach Gardens Florida 33418, U.S.A. Tel:+1-561-627-7947 Fax:+1-561-627-6615 jimber561@aol.com</p>	<p>Tianjin China No. 240 Baidi Road Nankai District Tianjin 300192 China Tel:+86-22-8789-4027 Fax:+86-22-8789-0344 wym@loop-tj.com</p>

© 2010 Loop Telecommunication International, Inc.
Version 68 02 APR 2010

All Rights Reserved
Subject to change without notice