



# Loop-AM3410 ACCESS MULTIPLEX

## Description



Loop-AM3410 is an Access Multiplexer that can combine various digital access interfaces into a single E1 or T1 line for convenient transport and switching. Interfaces include MDSL, and U type. These interfaces are compatible with other Loop products such as Loop-H 3900 for MDSL and Loop-U 3500 for U. Up to 31/24 time slots for the MDSL interface are then multiplexed to fill an E1/T1 line, with full flexibility of time slot assignment. Up to 2 time slots for the U interface are then multiplexed to fill an E1/T1 line, with full flexibility of time slot assignment.

## Features

- 2 slots available for 2 plug-in types:
  - a. 8-port or 4-port U interface compatible to Loop-U 3500
  - b. 3-port MDSL interface compatible to Loop-H 3900 with line power option
- Any combinations of  $n \times 64$  Kbps data streams can be multiplexed to fill an E1 or T1 line
- Optional Connection to LAN/WAN or host services
- Remote configuration and diagnostics
- Optional GUI NMS with LoopView
- Optional in-band 64-Kbps management
- 2-line by 40-character LCD and key pad for local administration, monitoring, and maintenance
- LED indicators for each port
- Single AC or DC plug-in modules
- Remote download of software
- SNMP Network Management Systems or simple terminal supervisory port

Loop-AM3410 supports local control and diagnostics by using 2-line by 40-character LCD display and keypads on the front panel, or by using a VT-100 terminal connected to the console port. Loop-AM3410 also supports Ethernet, SLIP, Telnet, and SNMP, so that it can be controlled and diagnosed from remote locations as well. Optional in-band management channel and LoopView with GUI are available. In addition to the LCD display, there are one status LED for each U, MDSL interface, and 4 LEDs for the E1 line.

**CERTIFIED  
ISO-9001**

## Ordering Information

To specify options, choose from list below:

Model	Description	Note
Loop-AM3410-E1	Main Unit with E1 Interface	Must select a main unit with E1 or T1.
Loop-AM3410-T1	Main Unit with T1 Interface	
Loop-AM3410-4U	4-Port IDSL plug-in Module	
Loop-AM3410-8U	8-Port IDSL plug-in Module	
Loop-AM3410-3H	3-Port MDSL plug-in Module	
Loop-AM3410-3HP5	3-Port MDSL plug-in Module with sealing current source	For SD –48Vdc power module only
Loop-AM3410-SNMP	Ethernet plug-in Module	Optional
Loop-AM3410-SA	Single AC Power Module	Select AC or DC Module.
Loop-AM3410-SD	Single DC Power Module	For AC choose an appropriate power cord.

### Accessories

#### User's Manual

Loop-AM3410-UM	User's Manual (optional, paper copy). A CD version of the manual is already included as standard equipment.
----------------	---

#### Power Cord

Loop-ACC-PC-USA	AC power cord for Taiwan/USA
Loop-ACC-PC-EU	AC power cord for Europe
Loop-ACC-PC-UK	AC power cord for the UK
Loop-ACC-PC-AUS	AC power cord for Australia
Loop-ACC-PC-CH	AC power cord for China

For example:

Loop-AM3410-E1

Loop-AM3410-U

Loop-AM3410-SA

For model 3410 for E1 interface with one 8-port IDSL plug-in module, and one single AC power.

## Loop-AM3410 Access Multiplex Product Specifications

### MDSL Line Interface

Up to 2 plug-in cards, with 3 MDSL interfaces per card.

Full duplex with adaptive echo cancellation MDSL line coding

Unconditioned 19-26 AWG twisted pair

Line rate: 272, 400, 528, 784, 1168, 1552, 2320 for data rates n x 64 Kbps.

**Note:** If T1, max n = 24. If E1, max n = 31.

### U Interface

Up to 2 plug-in cards

Type Full duplex with echo cancellation

Line Type Unconditioned twisted pair 19-26 AWG

Line Rate 64 or 128 Kbps

Line Coding 2B1Q

Connector RJ48C

### Network Line Interface - T1

Line Rate 1.544 Mbps ± 50 bps

Output Signal DSX1

Line Code	AMI/ B8ZS	Framing	D4/ ESF (selectable)
Input Signal	ABAM cable length up to 655 feet	Connector	RJ48C
<b><u>Network Line Interface - E1</u></b>			
Line Rate	2.048 Mbps $\pm$ 50 ppm	Framing	ITU G.704
Line Code	AMI/ HDB3 (selectable)	Connector	BNC/ RJ48C
Input Signal	ITU G.703 to -10dB	Electrical	75 ohm Coax/ 120 ohm twisted pair
Output Signal	ITU G.703	Jitter	ITU G.823

#### **Ethernet Interface (optional)**

Connector	RJ45 in rear
Protocol	Telnet and Embedded SNMP

#### **Front Panel**

Keypad	4 operation keys plus ACO key
LED	1 per U/ MDSL/ V.35-interface, ACO, Power, SYNC/TEST, LOF, BPV, RAI/AIS
LCD	2 lines by 40 characters

#### **Physical / Electrical**

Dimensions	432 x 88 x 298 mm (W×H×D)
Power	100-240V, 50/60 Hz AC or Single -48V DC, 30 Watts
Temperature	0-50°C
Humidity	0-95%RH (non-condensing)
Mounting	Desk-top stackable, 19" / 23" rack mountable

#### **Clock Source**

Internal, E1/ T1 Line

#### **Alarm Relay**

Alarm Relay, Fuse alarm, and performance alarm

#### **System configuration Parameters**

Active Configuration, Stored Configuration, and Default Configuration (Stored in Non-volatile Memory)

#### **Supervisor**

RS232, VT-100 - front panel	10 Base-T, SNMP - rear panel
SLIP - rear panel	In-band 64 Kbps

#### **Performance Monitor**

Performance Registers	Last 24 hours performance in 15 minutes interval and last 7 days in 24 hours summary
Separate Registers	12 MDSL ports, network, user, and remote site
Performance Reports	Reports include MDSL port unsync Date & Time, Errored Second, Unavailable Second, E1 Bursty Errored Second, Severe Errored Second, Degraded Minutes, and Controlled Slip Second. Also available in Statistics (%).
Alarm Queue	Containing 40 alarm records which record the latest alarm type, location, and date & time
Threshold	Bursty Seconds, Severely Errored Second, Degraded Minutes

#### **Diagnostics Test Line**

Loopback	E1/ T1 interface (Line Loopback, Payload Loopback, Local Loopback) MDSL interface (Payload Loopback, Local loopback) U interface (Local Loopback, Payload Loopback)
Test Pattern	E1/ T1 interface (2 <sup>15</sup> -1 PRBS, 3-in-24, 1-in-8, 2-in-8, 1:1 patterns) U/ MDSL/ DTE interface (2 <sup>11</sup> -1 BERT)

## Application Illustration:

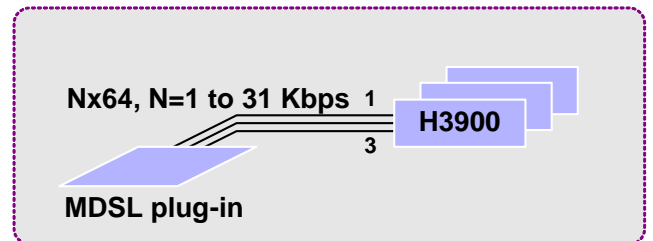
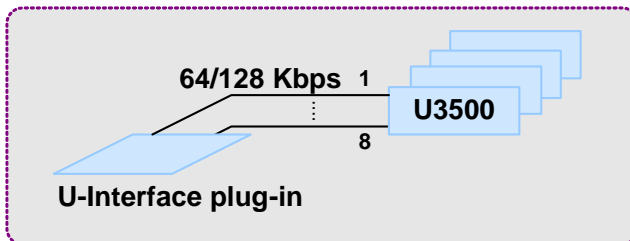
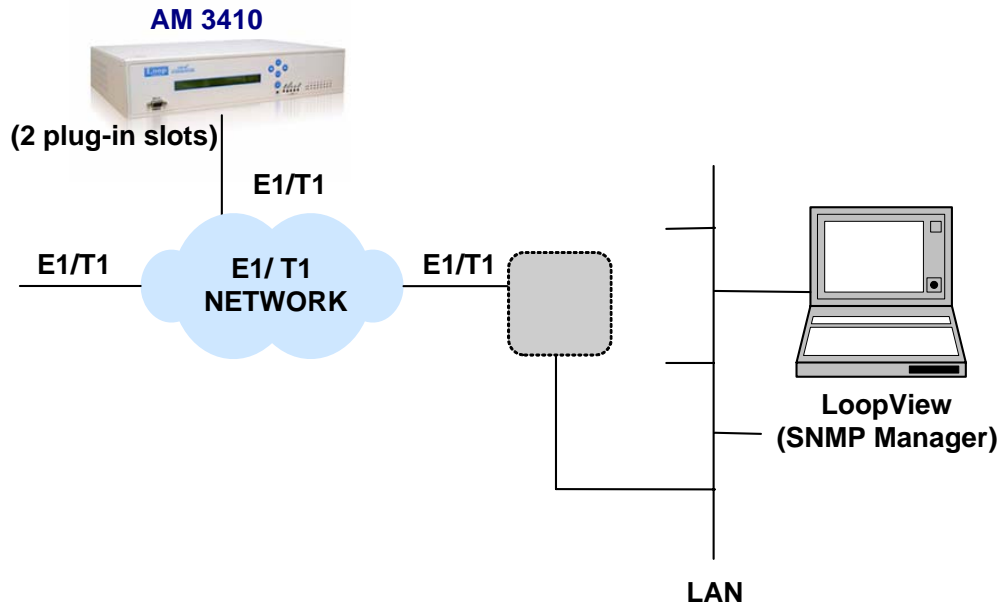

## LOOP TELECOMMUNICATION INTERNATIONAL, INC.

### Worldwide

8F, No. 8, Hsin Ann Road,  
Science-Based Industrial Park  
Hsinchu, Taiwan 300  
Tel:+886-3-578-7696  
Fax:+886-3-564-6272  
www.LoopTelecom.com  
sales@loop.com.tw

### Taipei, Taiwan

2F, No. 40, Section 2,  
Tuan-Hwa S. Road,  
Taipei, Taiwan 106  
Tel:+886-2-2784-4000  
Fax:+886-2-2754-2325

### North America

8 Carrick Road  
Palm Beach Gardens  
Florida 33418, U.S.A.  
Tel:+1-561-627-7947  
Fax:+1-561-627-6615  
jimber561@aol.com

### Suzhou China

Tel:+86-512-6252-0456  
Fax:+86-512-6252-7641  
Sales@looptech.com.cn

### Tianjin China

Tel:+86-22-8789-2753  
Fax:+86-22-8789-0344  
Loop@loop-tj.com